

DIXON ZTR[®]

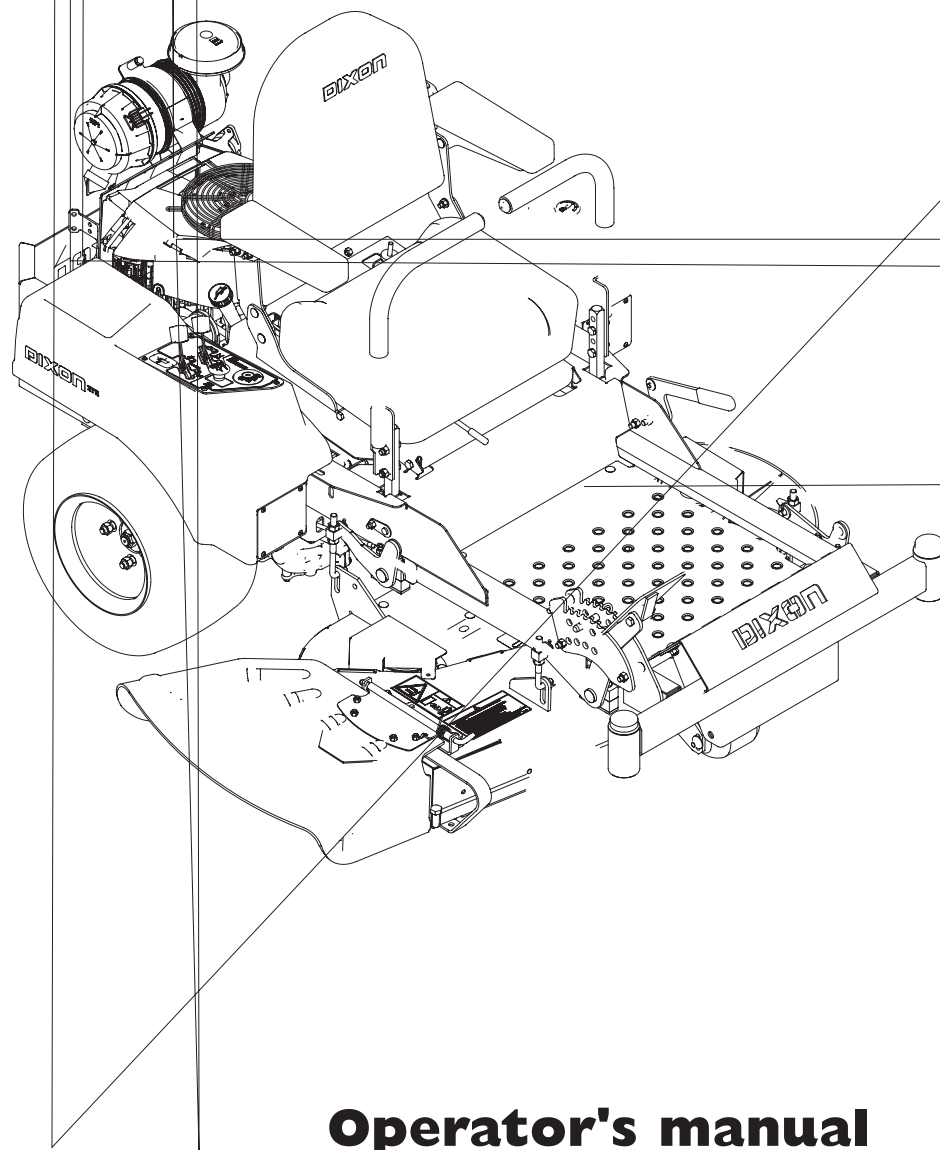

Operator's manual

RAM 44 / 968999551, RAM 50 / 968999552

RAM MAG 44 / 968999559, RAM MAG 50 / 968999561

RAM MAG 50 / 968999562, RAM MAG 44 / 968999650

RAM MAG 50 / 968999651

Please read the operator's manual carefully and make sure you understand the instructions before using the machine.

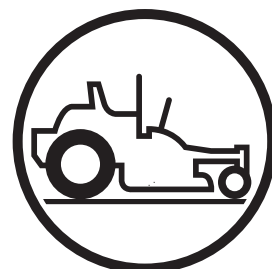

English

OPERATOR'S MANUAL

Contents

Contents	1	Maintenance	35
Introduction	3	Maintenance Schedule.....	35
Congratulations.....	3	Battery.....	37
General	3	Ignition System.....	38
Driving and Transport on Public Roads	3	Checking the Safety System	39
Towing	3	Checking the Engine's Cooling Air Intake	40
Operating	3	Checking and Adjusting the Throttle Cable.....	40
Good Service	4	Checking and Adjusting the Choke Cable.....	40
Manufacturing Number	4	Replacing the Air Filter.....	41
Symbols and Decals	5	Replacing the Fuel Filter	44
Safety Instructions	7	Checking the Fuel Pump's Air Filter.....	44
General Operation	7	Checking Tire Pressures.....	44
Personal Safety Equipment	9	Checking the Parking Brake.....	45
Slope Operation.....	9	Checking the V-belts	45
Children.....	10	Deck belt	45
Maintenance	11	IZT belt.....	46
Transport.....	14	Checking the Blades	48
Customer responsibilities.....	15	Adjusting the Mower Deck	50
Controls	16	Cleaning and Washing	52
Control Locations	16	Caster Wheels.....	52
1. Parking Brake	17	Hardware.....	52
2. Motion Control Levers.....	17	Parking brake	53
3. Fuel Shut Off Valve.....	18	Tracking adjustment.....	53
4. Seat adjustment knobs	18	Lubrication	54
5. Refueling	19	Lubrication Schedule.....	54
6. By pass linkage.....	20	General	54
7. Fuses	20	Lubricating the Cables	55
8. Hour Meter	21	Lubricating in Accordance with the Lubrication	
9. Choke Control	21	Schedule	55
10. Ignition Switch.....	21	Trouble Shooting Guide	61
11. Throttle Control	22	Storage	64
12. Blade switch.....	22	Winter Storage	64
13. Cutting height pedal.....	23	Service	64
Accessories.....	23	Wiring diagram	65
Operation	24	Technical Data	66
Training	24	Accessories.....	74
Before Starting	25	Torque Specifications.....	74
Starting the Engine	25	Conformity Certificates	75
To start an engine with a weak battery	29	USA requirements.....	75
Running.....	30	CE requirement.....	75
Operating on hills.....	31	Service Journal	76
Mowing Tips.....	32	Delivery Service	76
Stopping the Engine.....	33	After the First 5-8 Hours.....	77
Moving by Hand.....	34	25-Hour Service	78
		50-Hour Service	79
		100-Hour Service	80
		300-Hour Service	81
		At Least Once Each Year.....	82
		Warranty	83



WARNING!

Failure to follow cautious operating practices can result in serious injury to the operator or other persons. The owner must understand these instructions, and must allow only trained persons who understand these instructions to operate the mower. Each person operating the mower must be of sound mind and body and must not be under the influence of any mind altering substance.



WARNING!

INTRODUCTION

Introduction

Congratulations

Thank you for purchasing a Dixon ride-on mower. This machine is built for the greatest efficiency and rapid mowing primarily of large areas. Controls in one place and a hydrostatic transmission regulated by steering controls also contribute to the machine's performance.

This manual is a valuable document. Read the manual carefully before using or servicing the machine. Following the instructions (use, service, maintenance, etc.) by all who operate this machine can considerably increase the lifespan of your machine and even increase its resale value. It is also very important to follow the instructions for the safety of you and others.

If you sell your machine, be sure to give the operator's manual to the new owner.

The final chapter of this operator's manual comprises a Service Journal. Ensure that service and repair work is documented. A well kept service journal reduces service costs for the season-based maintenance and affects the machine's resale value. Please contact your dealer for more information. Take the operator's manual along when the machine is left to the workshop for service.

General

In this operator's manual, left and right, backward and forward are used in relation to the machine's normal driving direction.

Continuous dedication to improve our products require that specifications and design are subject to change without notice.

Driving and Transport on Public Roads

Check applicable road traffic regulations before transporting on public roads. If the machine is transported, you must always use approved fastening equipment and ensure that the machine is well anchored. DO NOT operate this machine on public roadways.

Towing

Do not tow this machine, it may cause damage to the drive system.

Do not tow any trailers, etc with this mower. They may jackknife or overturn causing damage to the mower and possibly serious injury to the operator.

Operating

This machine is constructed only for mowing grass on lawns and other free and even ground without obstacles such as stones, tree stubs, etc. The machine can also be used for other tasks when equipped with special accessories provided by the manufacturer, for which the operating instructions are provided in conjunction with delivery. All other types of use are incorrect. The manufacturer's directions concerning operation, maintenance, and repairs must be carefully followed.

Lawnmowers and all power equipment, can be potentially dangerous if used improperly. Safety requires good judgement, careful use in accordance with these instructions and common sense.

The machine must only be operated, maintained, and repaired by persons that are familiar with the machine's special characteristics and who are well versed in the safety instructions. Use only approved repair parts to maintain this machine.

Accident prevention regulations, other general safety regulations, occupational safety rules, and traffic regulations must be followed without fail.

Unauthorized modifications to the design of the machine may absolve the manufacturer from liability for any resulting personal injury or property damage.

INTRODUCTION

Good Service

Dixon's products are sold all over the world and only in specialized retail stores with complete service. This ensures that you as a customer receive only the best support and service. Before the product is delivered, the machine has, for example, been inspected and adjusted by your retailer, see the certificate in the Service Journal in this operator's manual.

When you need spare parts or support in service questions, warranty issues, etc., please consult the following professional:

This Operator's Manual belongs to the machine with manufacturing number:	Engine	Transmission

Manufacturing Number

The machine's manufacturing number can be found on the printed plate affixed to the left in the engine compartment. Stated on the plate, from the top are:

- The machine's type designation (I.D.).
- The manufacturer's type number (Model).
- The machine's serial number (Serial no.)

Please state the type designation and serial number when ordering spare parts.

The engine's manufacturing number is stamped on one of the valve covers.

The plate states:

- The engine's model.
- The engine's type.
- Code

Please state these when ordering spare parts.

The Hydro Drive IZ gears have a barcode decal affixed to the rear of the gears.

These symbols are found on the machine and in the operator's manual.
Study them carefully so that you know what they mean.



Used in this publication to notify the reader of a risk of does not follow instructions given in the manual.

, particularly if the reader



Used in this publication to notify the reader of a risk of follow instructions given in the manual. Used also when there is a potential for misuse or misassembly. , particularly if the reader does not



Reverse



Neutral



Fast



Slow



Choke



Fuel



Warning!



Parking brake



CE conformity marking. Only for European market



Warning! Rotating blades, keep away from the discharge deck



Do not touch rotating parts



Battery acid is corrosive, explosive, and flammable

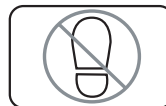

Do not stand here



Noise emissions to the surroundings in accordance with the European Union's directive. The machine's emission is stated in the chapter TECHNICAL DATA and on the decals.



Use protective glasses



Use protective gloves

Only machines for European market

Read
Operator's
Manual.

Shut off engine
& remove key
before
performing any
maintenance or
repair work.

Keep a safe
distance from
the machine.

Use on
slopes no
greater
than 10°.

No
passengers

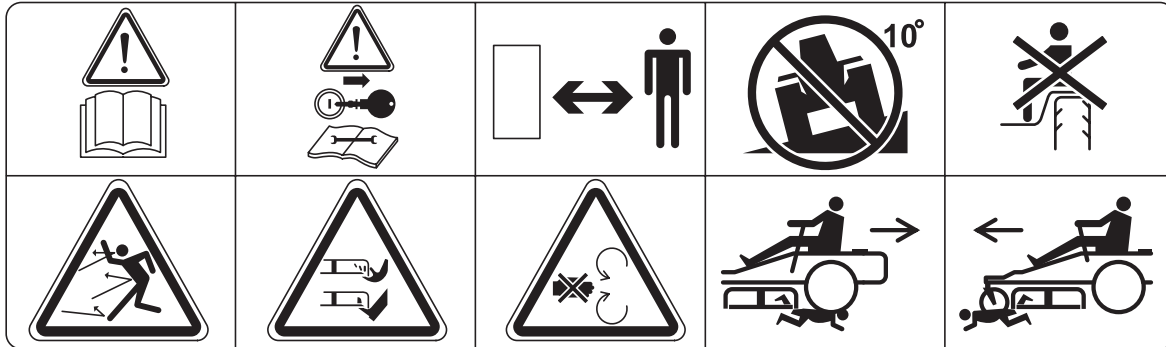

Whole
body
exposure
to thrown
objects.

Severing
of fingers
& toes.

Do not open
or remove
safety
shields while
engine is
running.

Careful
backing up,
watch for
other people.

Careful going
forward,
watch for
other people.



Moving sharp blades
under cover

Safety Instructions

These instructions



should be emphasized. It

IMPORTANT: Failure to follow these instructions could result in serious injury or death.

KEEP HANDS AND FEET AND OTHER BODY PARTS AWAY FROM THE DISCHARGE CHUTE. FAILURE TO FOLLOW THESE SAFETY INSTRUCTIONS COULD RESULT IN SERIOUS INJURY OR DEATH.

General Operation

- Read, understand, and follow all safety instructions and warnings in this manual before operating the machine.
- Do not put hands or feet into the discharge chute or under the discharge chute cover.
- Only allow responsible persons familiar with the machine to operate the machine.
- Clear the area of toys, wire, etc., before mowing, and thrown by the machine.
- Be sure the area is clear of people and pets before operating the machine, and if anyone enters the mowing area, stop the machine immediately.
- Never carry passengers. The machine is only intended for use by one person.
- Do not mow in reverse unless necessary. Always look back before and while backing up.
- Never direct discharge of grass or other material at anyone. Avoid discharging against a wall or obstruction. Grass or other material may ricochet back toward the operator. Stop the blades when cutting near people or animals.

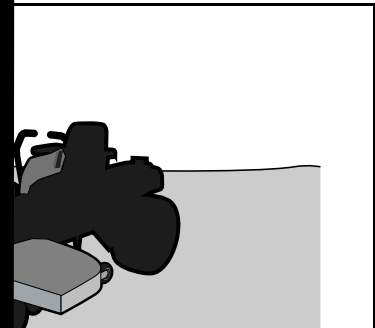

entire grass catcher, discharge chute, and other safety devices in place before mowing.

- Slow down before turning.
- Never leave a running machine unattended. Always turn off blades, engage parking brake, stop engine, and remove keys before dismounting.

SAFETY INSTRUCTIONS

- Disengage blades when not mowing. Shut off engine and wait for all parts to come to a complete stop before cleaning the machine, removing the grass catcher, or unclogging the discharge guard.
- Operate machine only in daylight or good artificial light.
- Do not operate the machine while under the influence of alcohol or drugs.
- Watch for traffic when operating near or crossing roadways.
- Use extra care when loading or unloading the machine into a trailer or truck.
- Always wear eye protection when operating machine.
- Data indicates that operators, age 60 years and above, are involved in a large percentage of riding mower-related injuries. These operators should evaluate their ability to operate the riding mower safely enough to protect themselves and others from serious injury.
- Follow the manufacturer's recommendation for wheel weights or counterweights.
- Never allow children or other persons not trained in the use of the machine to use or service it. Local laws may regulate the age of the user. Anyone who operates this machine should first read and understand this Operator's Manual.
- Keep machine free of grass, leaves or other debris build-up which can touch hot exhaust / engine part and burn. Do not allow the mower deck to plow leaves or other debris which can cause build-up to occur. Clean any oil or fuel spillage before operating or storing the machine. Allow machine to cool before storage.



WARNING!

Engine exhaust and certain vehicle components contain or emit chemicals considered to cause cancer, birth defects, or other reproductive system damage. The engine exhaust contains carbon monoxide, which is a odorless, colorless, poisonous gas. Do not use the machine in enclosed spaces.

SAFETY INSTRUCTIONS

Personal Safety Equipment



WARNING!

When using the machine, approved personal protective equipment (shown in illustrations) shall be used. Personal protective equipment cannot eliminate the risk of injury but it will reduce the degree of injury if an accident does happen. Ask your retailer for help in choosing the right equipment.

- Make sure that you have first aid equipment close at hand when using the machine.
- Never use the machine when barefoot. Always wear protective shoes or boots, preferably with steel toecaps.
- Always wear approved protective glasses or a full visor when assembling or driving.
- Always wear gloves when handling the blades.
- Never wear loose clothing that can get caught in moving parts.
- Use ear protectors to avoid damage to hearing.

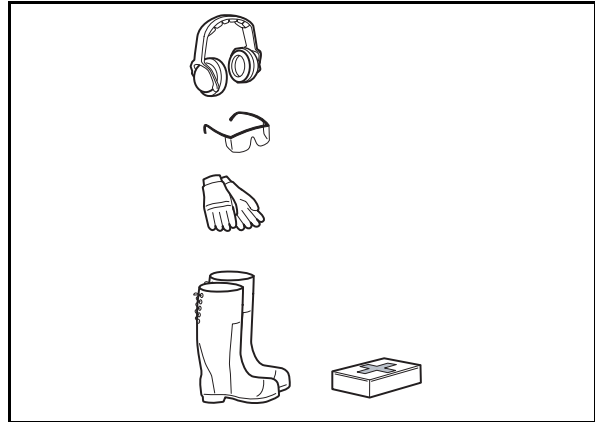

8011-670

Personal protective equipment

Slope Operation

Slopes are a major factor related to loss of control and tip-over accidents, which can result in severe injury or death. Operation on all slopes requires extra caution. If you cannot back up the slope or if you feel uneasy on it, do not mow it.

- Mow up and down slopes (10 degrees maximum), not across.
- Watch for holes, ruts, bumps, rocks, or other hidden objects. Uneven terrain could overturn the machine. Tall grass can hide obstacles.
- Choose a low ground speed so that you will not have to stop while on the slope.
- Do not mow on wet grass. Tires may lose traction.
- Avoid starting, stopping, or turning on a slope. If the tires lose traction, disengage the blades and proceed slowly straight down the slope.
- Keep all movement on the slopes slow and gradual. Do not make sudden changes in speed or direction, which could cause the machine to roll over.

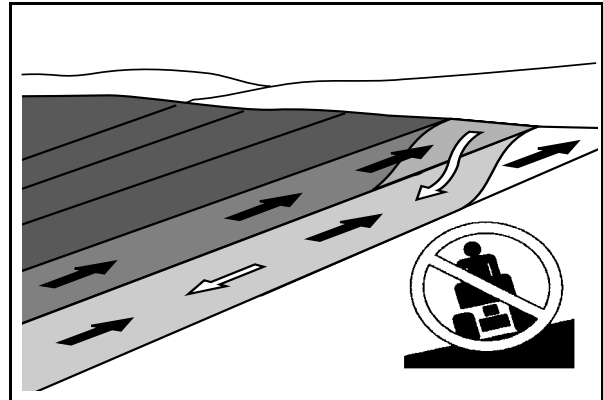

6003-004

Mow up and down, not side-to-side



WARNING!

Do not drive up or down hills with slopes greater than 10 degrees. And do not drive across any slopes.



SAFETY INSTRUCTIONS

Maintenance



WARNING!

The engine must not be started when the driver's floor plate or any protective plate for the mower deck's drive belt is removed.

Safe Handling of Gasoline

To avoid personal injury or property damage, use extreme care in handling gasoline. Gasoline is extremely flammable and the vapors are explosive.

- Extinguish all cigarettes, cigars, pipes, and other sources of ignition.
- Use only approved gasoline container.
- Never remove gas cap or add fuel with the engine running. Allow engine to cool at least two (2) minutes before refueling.
- Never fuel the machine indoors.
- Never store the machine or fuel container where there is an open flame, spark, or pilot light such as on a water heater or other appliances.
- Never fill containers inside a vehicle or on a truck or trailer bed with plastic liner. Always place containers on the ground away from your vehicle when filling.
- Remove gas-powered equipment from the truck or trailer and refuel it on the ground. If this is not possible, then refuel such equipment with a portable container, rather than from a gasoline dispenser nozzle.
- Keep the nozzle in contact with the rim of the fuel tank or container opening at all times until fueling is complete. Do not use a nozzle lock-open device.
- If fuel is spilled on clothing, change clothing immediately.
- Never overfill fuel tank. Replace gas cap and tighten securely.
- Do not start the engine near spilled fuel.
- Never use gasoline as a cleaning agent.
- If leaks arise in the fuel system, the engine must not be started until the problem has been resolved.
- Check the fuel level before each use and leave space for the fuel to expand, because the heat from the engine and

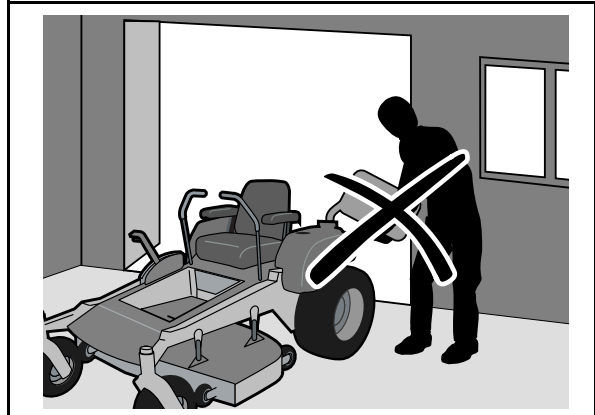

8011-516

Never fill the fuel tank indoors



WARNING!

The engine and the exhaust system, become very hot during operation.

Risk for burns if touched.

Allow engine and exhaust system to cool at least two (2) minutes before refueling

SAFETY INSTRUCTIONS

the sun may otherwise cause the fuel to expand and overflow.

General Maintenance

- Never operate machine in a closed area.
- Keep all nuts and bolts tight to be sure the equipment is in safe working condition.
- Never tamper with safety devices. Check their proper operation regularly.
- Keep machine free of grass, leaves, or other debris build-up. Clean oil or fuel spillage and remove any fuel-soaked debris. Allow machine to cool before storing.
- If you strike a foreign object, stop and inspect the machine. Repair, if necessary, before restarting.
- Never make any adjustments or repairs with the engine running. Prevent starting by removing the spark plug wire before making adjustments or carrying out maintenance.
- Check grass catcher components and the discharge guard frequently and replace with manufacturer's recommended parts, when necessary.
- Mower blades are sharp. Wrap the blade or wear gloves, and use extra caution when servicing them.
- Check brake operation frequently. Adjust and service as required.
- Maintain or replace safety and instruction labels, as necessary.
- Do not modify safety equipment. Check regularly to be sure it works properly. The machine must not be driven with defective or unmounted protective plates, protective cowlings, safety switches, or other protective devices.
- Do not change the settings of governors and avoid running the engine with overly high engine speeds. If you run the engine too fast, you risk damaging the machine components.
- Be very careful when handling battery acid. Acid on skin can cause serious corrosive burns. If you spill battery acid on your skin, rinse immediately with water.

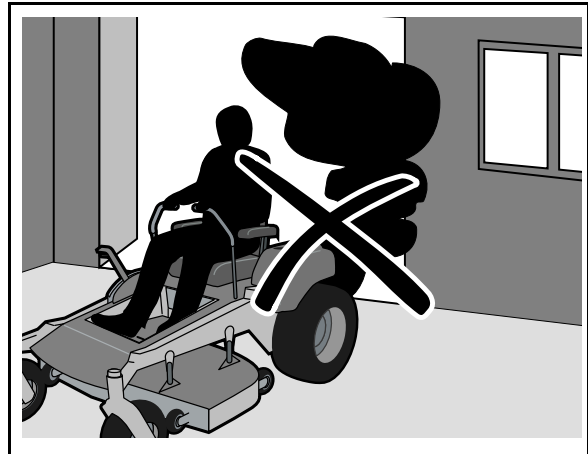

8011-515

Never drive the machine in an enclosed space

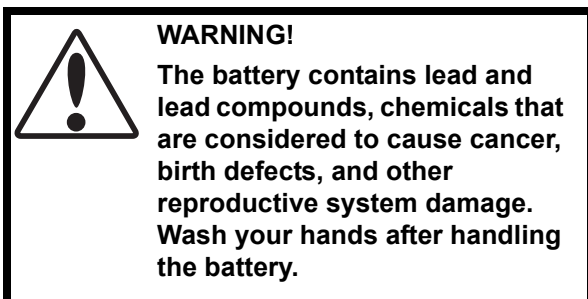

SAFETY INSTRUCTIONS

- Acid in the eyes can cause blindness, contact a doctor immediately.
- Be careful when servicing the battery. Explosive gases form in the battery. Never perform maintenance on the battery when smoking or near open flames or sparks. The battery can explode and cause serious injury/damage.
- Ensure that nuts and bolts, especially the fastening bolts for the blade attachments, are properly tightened, torqued and that the equipment is in good condition.
-
- Sparking can occur when working with the battery and the heavy cables of the starter circuit. This can cause battery explosion, fire or eye injury. Sparking in this circuit can not occur after the chassis cable (normally negative, black) is removed from the battery.

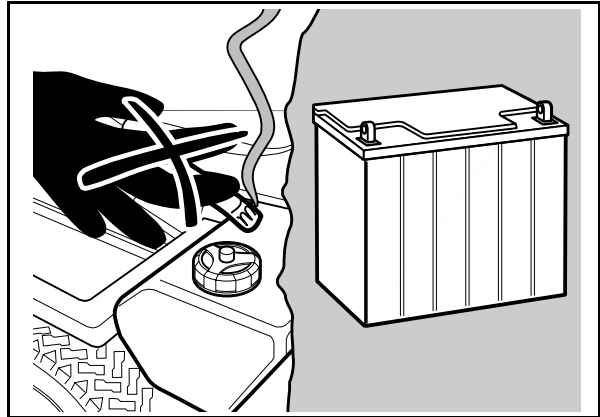

6003-009

Do not smoke when performing maintenance on the battery. The battery can explode and cause serious injury/damage

- Use protective goggles.
- Ensure that the fuel filler cap is mounted tightly and no flammable substances is stored in an open vessel.
- Never work with the starter circuit if there is spilled fuel.
- Disconnect the chassis cable from the battery first and reconnect it last.
- Do not make a bridge short circuit across the starter relay to run the starter.
- Never use the machine indoors or in spaces lacking proper ventilation. The exhaust fumes contain carbon monoxide, an odorless, poisonous, and lethal gas.
- Stop and inspect the equipment if you run over or into anything. If necessary, make repairs before starting.
- Never make adjustments with the engine running.
- The machine is tested and approved only with the equipment originally provided or

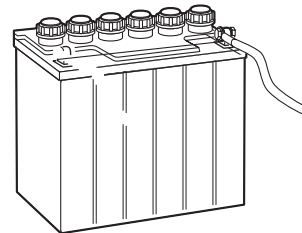

SAFETY INSTRUCTIONS

recommended by the manufacturer. Only use approved repair parts for the machine.

- The blades are sharp and can cause cuts and gashes. Wrap the blades or use protective gloves when handling them.
- Check the parking brake's functionality regularly. Adjust and service as necessary.
- The mulch blades should only be used in familiar areas when higher quality mowing is desired.
- Reduce the risk of fire after using the machine by removing grass, leaves, and other debris that may have accumulated on the machine. Allow the machine to cool before putting it in storage.
- Clean deck and underside of deck after each use and, avoid spraying engine and electrical components with water.



8011-644

Clean the machine regularly

Transport

- The machine is heavy and can cause serious crushing injuries. Be extra cautious when it is loaded on or unloaded from a vehicle or trailer.
- Use an approved trailer to transport the machine. Activate the parking brake, turn off the fuel supply, and fasten the machine with approved fastening devices, such as bands, chains, or straps, when transporting.
- Do not operate this machine on public roadways.
- Check and abide by local traffic regulations before transporting the machine on any road.
- Do not tow this machine, it may cause damage to the drive system.
- Do not tow any trailers, etc. with this mower. They may jackknife or overturn causing damage to the mower and possibly serious injury to the operator.
- Load the unit onto truck or trailer by driving up ramps of suitable strength using a slow speed. Do not lift! The machine is not intended to be lifted by hand.

IMPORTANT INFORMATION

The parking brake is not sufficient to lock the machine in place during transport. Ensure that the machine is well fastened to the transport vehicle. Always reverse the machine onto the transport vehicle to avoid tipping it over.

SAFETY INSTRUCTIONS

Customer responsibilities

- Read and observe the safety rules.
- Follow a regular schedule in maintaining, caring for and using your mower.
- Follow the instructions under "Maintenance" and "Storage" sections of this owner's manual.
- This machine has no brain. Use yours!



WARNING!

This mower is equipped with an internal combustion engine and should not be used on or near any unimproved forest-covered, bush-covered or grass-covered land unless the engine's exhaust system is equipped with a spark arrester meeting applicable local or state laws (if any). If a spark arrester is used, it should be maintained in effective working order by the operator.

A spark arrester for the muffler is available through your authorized Dixon dealer.

This operator's manual describes the Dixon Zero Turn Rider. The rider is fitted with a Briggs & Stratton, Kohler, Honda or Kawasaki four stroke V-twin engine developing 20 - 26 horse power.

Transmission from the engine is made via two belt-driven hydraulic transaxles, one for each drive wheel. Using the left and right steering controls, the flow is regulated and thereby the direction and speed.

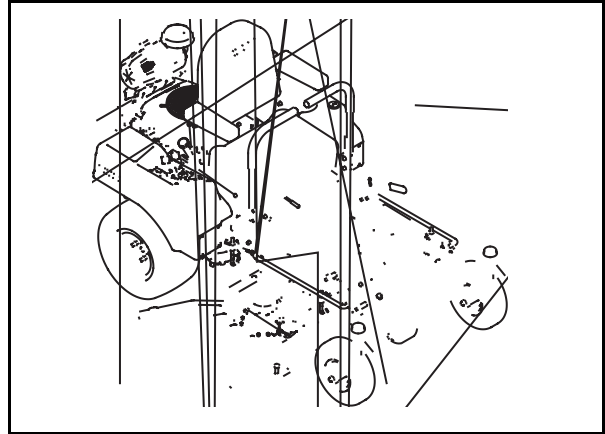

Control Locations

	Page		Page
1. Parking brake	17	8. Hour meter	21
2. Motion control levers	16	9. Choke control	21
3. Fuel shut off valve	18	10. Ignition switch	21
4. Seat adjustment bolts	18	11. Throttle control	22
5. Fuel tank cap	19	12. Blade switch	22
6. By pass linkage	19	13. Cutting height pedal	23
7. Fuses	20		



The parking brake is found on the left of the machine. Pull the lever backward to activate the brake and forward to release it.

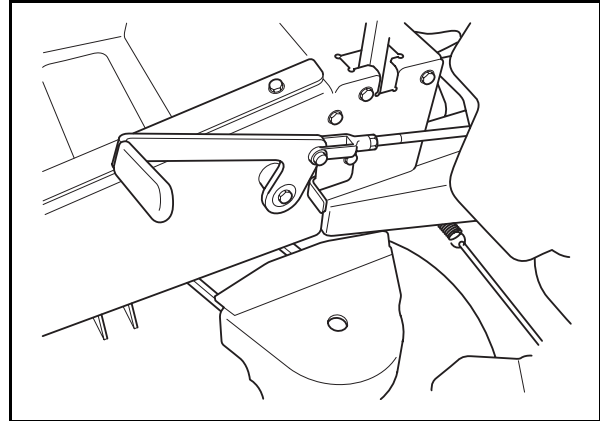

8011-711

Parking brake not activated

The machine's speed and direction are continuously variable using the two steering controls. The steering controls can be moved forward or backward about a neutral position. Furthermore, there is a neutral position, which is locked if the steering controls are moved outward.

When both controls are in the neutral position (N), the machine stands still.

By moving both controls an equal amount forward or backward, the machine moves in a straight line forward or backward respectively.

In order, for example, to turn right while moving forward, move the right control towards the neutral position. The rotation of the right wheel is reduced and the machine turns to the right.

Zero turn can be achieved by moving one control backward (behind the neutral position) and carefully moving the other steering control forward from its neutral position. The rotation direction when zero turning is determined by which steering control is moved backward behind the neutral position. If the left steering control is pulled backward, the machine turns to the left. Use extra care when using this maneuver.

If the steering controls are in uneven

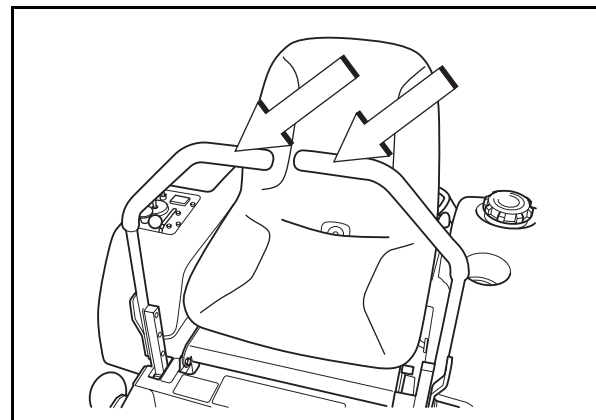

8011-789

Steering controls



positions when standing still or do not fit in the slots for moving the controls outward, they can be adjusted.

If the mower is not tracking straight, check the air pressure in both rear tires. Recommended air pressure is 15 psi. (1 bar) Tracking must be checked on a flat and level concrete or blacktop surface. If the unit still does not track straight contact your Dixon workshop for adjustments.

The fuel shut off valve is located under the fuel tank. The valve has two positions; ON and OFF.

With the machine off remove the two bolts holding the seat pan down and flip the seat forward.

The seat can be adjusted lengthways. When making adjustments, loosen the four bolts under the seat pan, after which the seat can be moved backward or forward.

Once the seat is adjusted to your liking. Flip the seat back down and rebolt the seat pan to the frame.

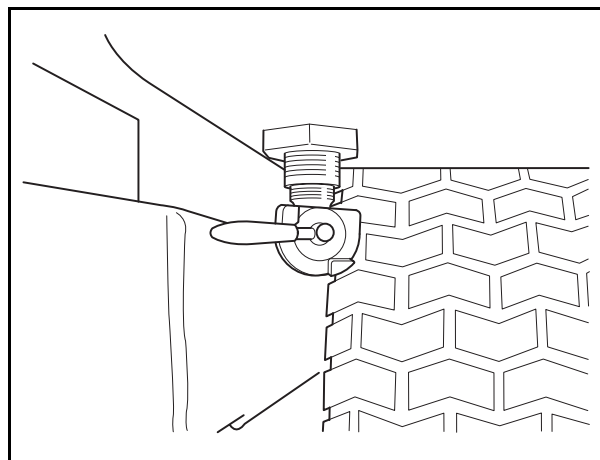
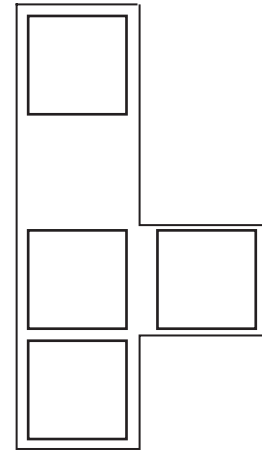

8011-712

Fuel shut off valve in OFF position

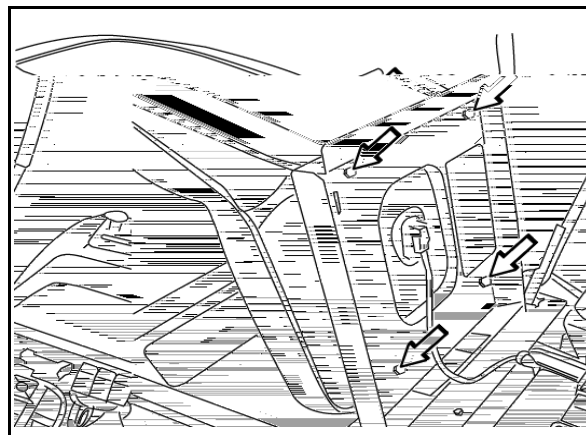

CZ-1

Lengthways adjustment

Read the safety instructions before refueling. The machine has one fuel tank, just behind the seat. The tank volume is 5.4 gallons (20.4 liters).

Make sure the fuel cap is properly tightened and the cap gasket is not damaged.

The engine will run on a minimum of 85-octane unleaded gasoline (no oil mix). Environmentally adapted alkylate gasoline can be used beneficially. See also Technical Data concerning ethanol fuel. Methanol fuel is not allowed.

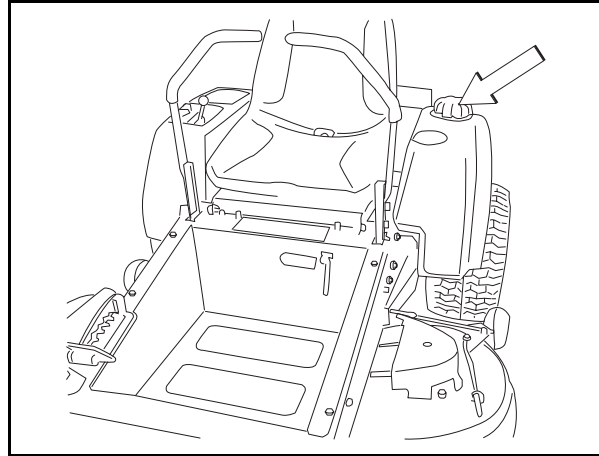

8011-761

Fuel tank



When operating in temperatures below 32° F. (0° C.), use fresh, clean winter grade gasoline to help insure good cold weather starting.

When pushing or pulling the mower, be sure to engage the IZT (Integrated Zereturn Transaxle) bypass linkages. The IZT bypass linkages are located on the rear of the frame, below the rear engine guard.

- Raise the deck into the highest cutting position.

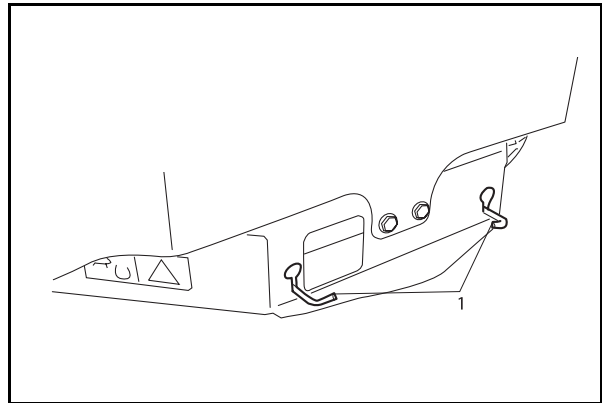

CZ10-2

1. IZT Bypass linkage

Bypass linkages

- Pull the IZT bypass linkages out and into the slots and release so that it is held in the bypass position.
- To reengage the IZT's to drive, reverse the above procedure.

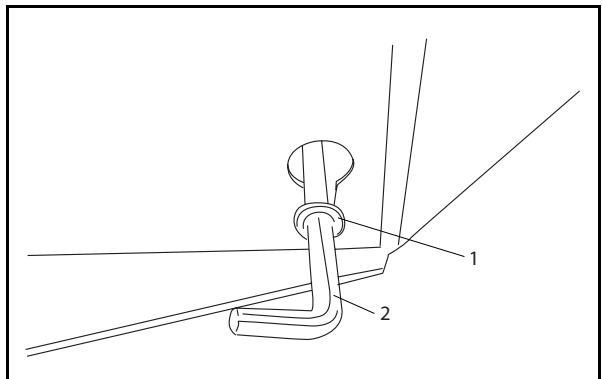

CZ12

1. Head outside of rear deck

2. IZT Bypass linkage in bypass position

Bypass position

The fuses are located in a holder at the right hand side of the battery compartment. They are flat pin fuses of the same type used in automobiles.

There are two fuses.

Fuse ratings and functions:

- 20 A, Primary fuse.
- 7.5 A, Mower deck coupling.

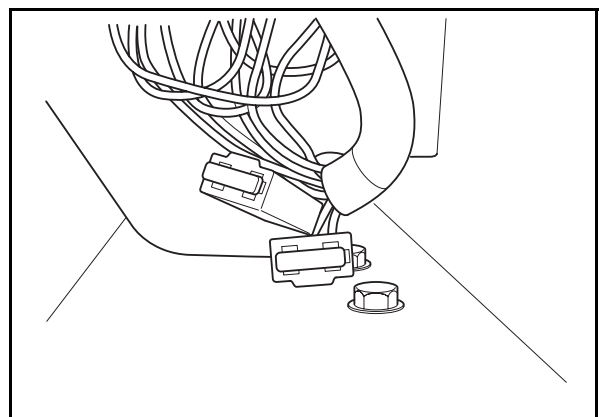

8011-483

Fuses

The hour meter displays the total operating time.

It will flash CHG OIL (Change Oil) at 50 hour intervals. The flash duration is one hour before and one hour after the interval. The CHG OIL icon will come on and shut off automatically. The hour meter can not be manually reset.

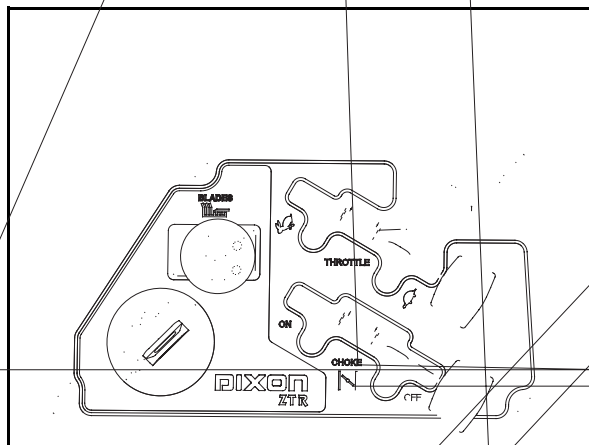

The choke control is used for cold starts in order to provide the engine with a richer fuel mixture.

For cold starts the control should be pulled out.

The ignition key is placed on the control panel and is used to start and stop the engine.

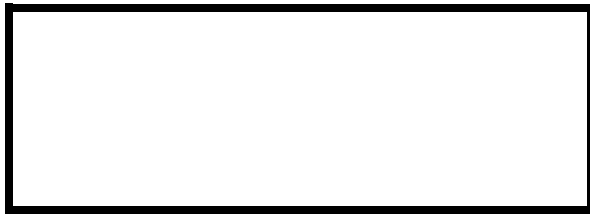

The throttle control regulates the engine speed and thereby the rate of rotation of the blades, assuming the blade switch is pulled out, see Engaging the Mower Deck.

In order to increase or decrease the engine speed, the control is moved forward or backward respectively.

Avoid idling the engine for long periods, as there is a risk of fouling the spark plugs.

best mower performance and battery charging. , for

In order to engage the mower deck, pull the knob out; the mower blades are disengaged when the knob is depressed.

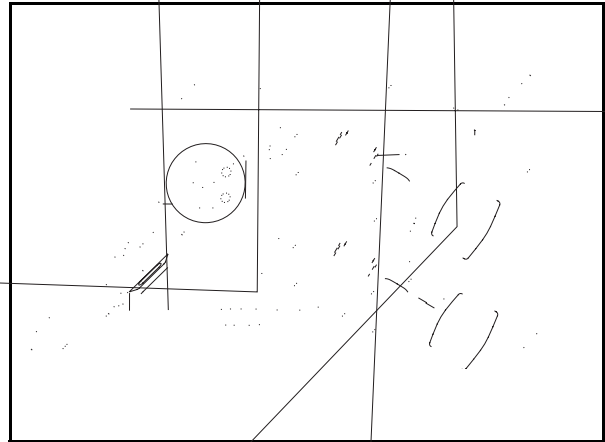

The cutting deck height is obtained by pressing the foot pedal lift arm forward and releasing the transport latch. Then lower the deck to the preset height. To raise the deck push forward on the foot pedal lift arm until the transport latch locks. The cutting height range is from 1 1/2" (38 mm) to 4 1/2" (114 mm) in 1/4" (6.4 mm) increments. The heights are measured from the ground up to the blade tip with the engine not running.

To change cutting heights move the pin on the cutting height plates to the desired height of cut.

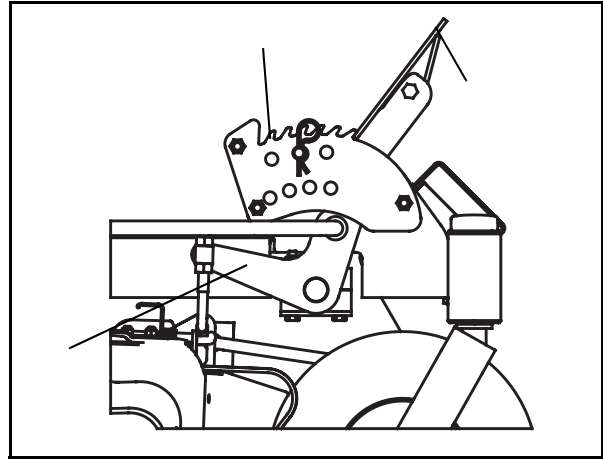

8050-152

1. Foot pedal
2. Lift arm
3. Height plate

Cutting height pedal

For mulching, there is a BioClip attachment available. This is mounted underneath the mower deck and consists of control plates and BioClip blades.

OPERATION

Operation

Read "Safety Instructions", the "Controls" section and following pages, if you are unfamiliar with the machine. Conduct all daily maintenance on the machine before starting.

Training

Zero turn mowers are far more maneuverable than typical riding mowers due to their unique steering capabilities.

We suggest when first operating the mower, use a reduced throttle speed and reduced ground speed by NOT moving control levers to the furthest forward or reverse positions during initial operation, or until operator becomes comfortable with controls. We also suggest first time users, or new users to ZeroTurn mowers to become familiar with the mowers movement on a hard surface, such as concrete or blacktop PRIOR to attempting to operate on turf. Until operator becomes comfortable with mower controls and zero turning capability, they may damage turf due to over aggressive maneuvers.

To move forward and backward

The direction and speed of the mowers movements is effected by the movement of the control lever(s) on each side of mower. The left control lever controls the left wheel. The right control lever controls the right wheel.

IMPORTANT INFORMATION

When control levers are in the reverse position they return to neutral when released. This may cause the mower to suddenly stop.

First time users should push mower (see "Moving by Hand" in the "Operation" section) to an open, flat area, without other people or vehicles/obstacles near by. In order to move unit under its own power, the operator must be in the seat, start engine (see " Before Starting" in "Operation" section), adjust engine speed to idle, disengage park brake, do not engage blades at this time, rotate control levers inward. As long as the control levers have not been moved forward or backwards, mower will not move. Slowly move both control levers forward slightly, this will allow mower to start moving forward in a straight line. Pull back on control levers to the neutral position and mower should stop moving. Pull back slightly on control levers, this will allow mower to start moving backwards. Push forward on control levers to the neutral position and mower should stop moving.

To turn to the right

While moving in a forward direction, pull the right lever back towards the neutral position while maintaining the position of the left lever, this will slow the rotation of the right wheel and cause the machine to turn in that direction.

To turn to the left

While moving in a forward direction pull the left lever back towards the neutral position while maintaining the position of the right lever, this will slow the rotation of the left wheel and cause the machine to turn in that direction.

To zero turn

While moving in a forward direction, first pull both control levers back until the mower stops or slows dramatically. Then by alternating one lever slightly to the forward position and the other in the reverse position.

OPERATION

4. Disengage the mower blades by depressing the blade switch.



Depress the contr

5. Move the steering controls outward to the locked (outer) neutral position.

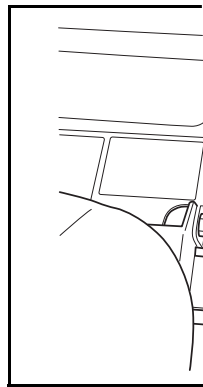

Steering controls in

neutr

6. Move the throttle to the middle position.

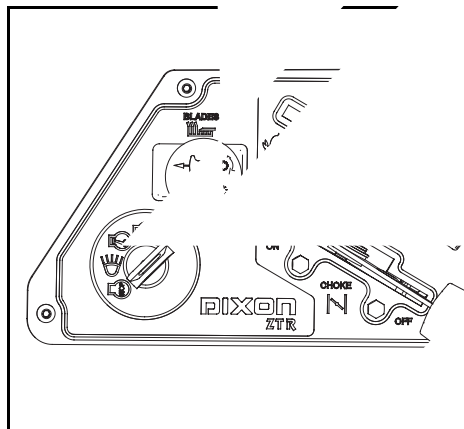

OPERATION

To start an engine with a weak battery

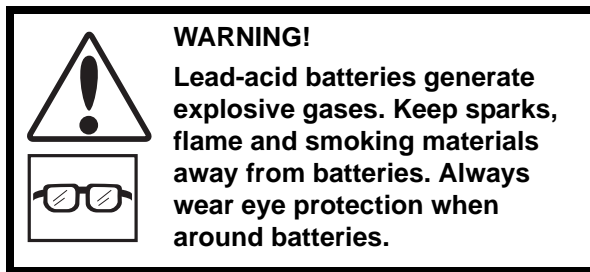

If your battery is too weak to start the engine, it should be recharged. (See “Battery” on page 37).

If “jumper cables” are used for emergency starting, follow this procedure:

IMPORTANT INFORMATION

Your mower is equipped with a 12-volt negative grounded system. The other vehicle must also be a 12-volt negative grounded system. Do not use your mower battery to start other vehicles. Do not allow vehicles to touch when using jumper cables.

To attach jumper cables

- Connect each end of the RED cable to the POSITIVE (+) terminal on each battery, taking care not to short against chassis.
- Connect one end of the BLACK cable to the NEGATIVE (-) terminal of the fully charged battery.
- Connect the other end of the BLACK cable to a good CHASSIS GROUND on the mower with the discharged battery, away from the fuel tank and battery.

To remove cables, reverse order

- Remove BLACK cable first from chassis and then from the fully charged battery.
- Remove RED cable last from both batteries.

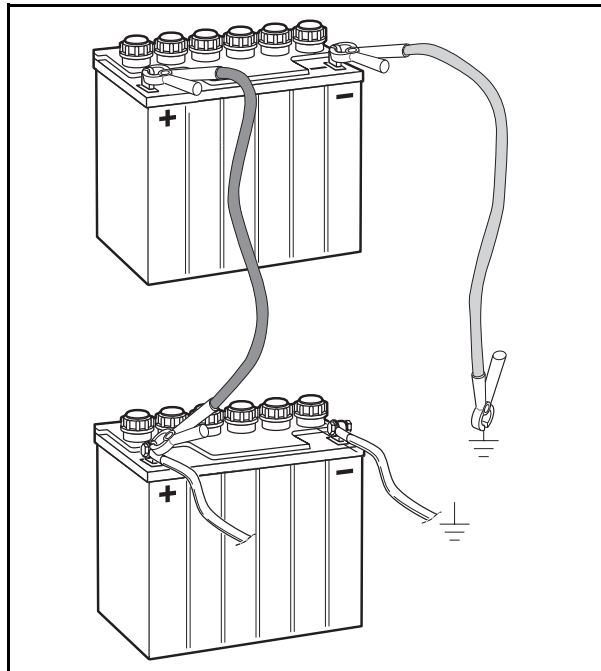

Jumper cables connection

8011-642

OPERATION

Running

1. Release the parking brake by moving the lever forward.

Your mower is equipped with an operator presence system. When the engine is running, any attempt by the operator to leave the seat without first setting the parking brake will shut off the engine.

2. Move the steering controls to the neutral position (N).

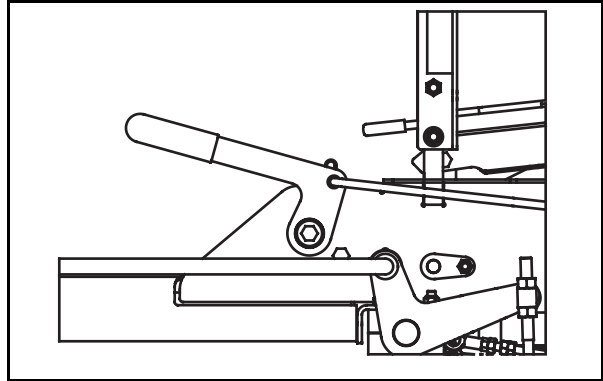

8050-155

Released parking brake

3. Select the cutting height by adjusting the cutting height pin. Release latch and lower deck to set cutting height.

IMPORTANT INFORMATION

The mower deck's anti-scalp rollers should be evenly adjusted.

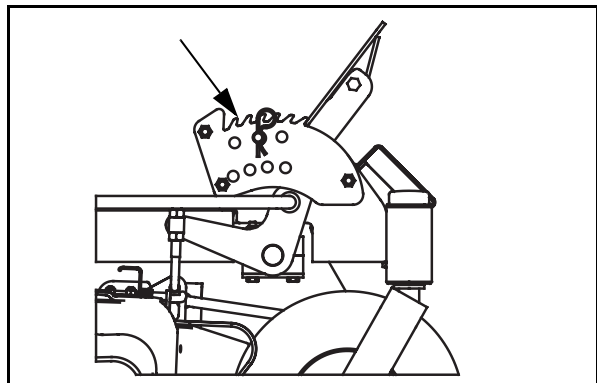

8050-152

Cutting height selection



WARNING!

Ensure that no one is near the machine when engaging the Blade switch.

4. Make sure the work area is free from objects that could be thrown by the rotating blades.
5. Engage the mower deck by pulling out the blade switch.
6. Move throttle control to full throttle.
7. The machine's speed and direction are continuously variable using the two steering controls. When both controls are in the neutral position, the machine stands still.

By moving both controls an equal amount forward or backward, the machine moves in a straight line forward

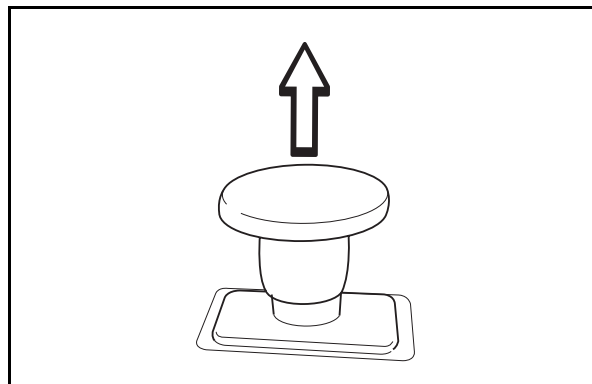

8011-669

Engaging the mower deck

OPERATION

or backward respectively.

In order, for example, to turn right while moving forward, move the right control towards the neutral position. The rotation of the right wheel is reduced and the machine turns to the right.

Turning on the spot can be achieved by moving one control backward (behind the neutral position) and carefully moving the other steering control forward from its neutral position.

Operating on hills

Read "Slope Operation " in the "Safety Instructions".



WARNING!
To prevent the machine from rolling over do not drive up or down hills with slopes greater than 10 degrees. And do not drive across any slopes.

- The slowest speed possible should be used before starting up or down hills.
- Avoid stopping or changing speed on hills.
- If stopping is absolutely necessary, pull drive levers into the neutral position and push to the outside of the unit and engage the park brake.

IMPORTANT INFORMATION
Control levers return to neutral when released. This may cause the mower to suddenly stop.

- To restart movement, release the park brake.
- Pull the control levers back to the center of the mower and press forward to regain forward motion.
- Make all turns slowly.

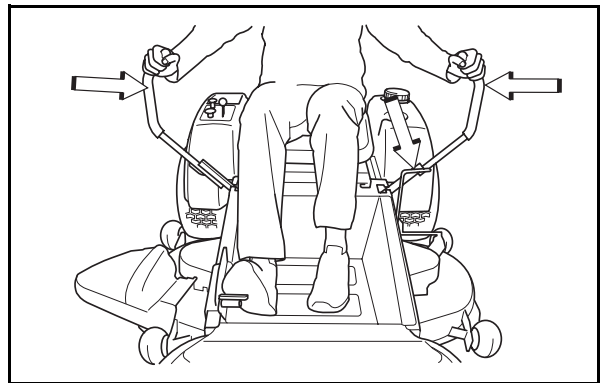

8011-772

Stopping conditions

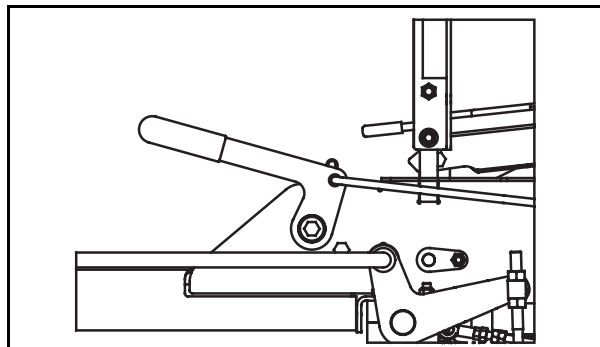

Released parking brake

8050-155

OPERATION

Mowing Tips

- Observe and flag rocks and other fixed objects to avoid collisions.
- Begin with a high cutting height and reduce it until the desired mowing result is attained.

The average lawn should be cut to 2 1/2" (64 mm) during the cool season and over 3" (76 mm) during the hot months. For healthier and better looking lawns, mow often after moderate growth.

For best cutting performance, grass over 6" (15 cm) in height should be mowed twice. Make the first cut relatively high; the second to the desired height.

- The mowing result will be best with a high engine speed (the blades rotate rapidly) and low speed (the rider moves slowly). If the grass is not too long and dense, the driving speed can be increased without negatively affecting the mowing result.
- The finest lawns are obtained by mowing often. The lawn becomes more even and the grass clippings more evenly distributed over the mown area. The total time taken is not increased as a higher operating speed can be used without poor mowing results.
- Avoid mowing wet lawns. The mowing result is poorer because the wheels sink into the soft lawn, clumps build, and the grass clippings fasten under the cowling.
- Hose the mower deck underside with water after each use. When cleaning, the mower deck should be raised into the transport position. Make sure the mower is cooled and the engine is off.
- Use compressed air to clean top surface of the deck. Avoid flooding water on top surface of deck engine or electrical components.
- When the mulching kit is used, it is important that the mowing interval is frequent.

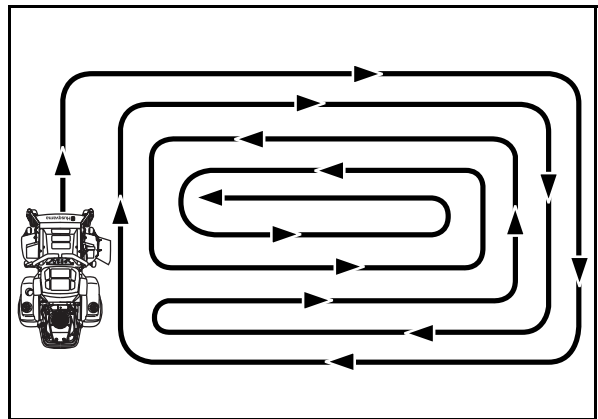
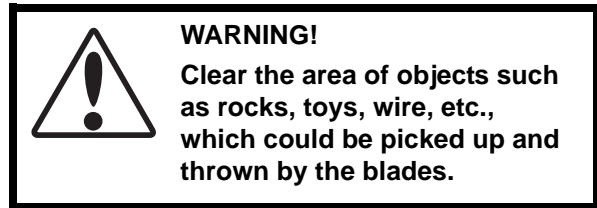

8011-603

Mowing patterns

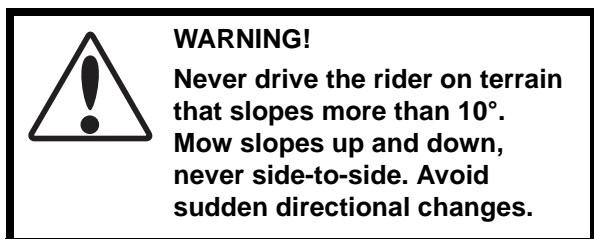

OPERATION

Stopping the Engine

Allow the engine to idle a minute in order to attain normal operating temperature before stopping it, if it has been worked hard. Avoid idling the engine for longer periods, as there is a risk of the spark plugs fouling.

1. Disengage the mower deck by depressing the blade switch.

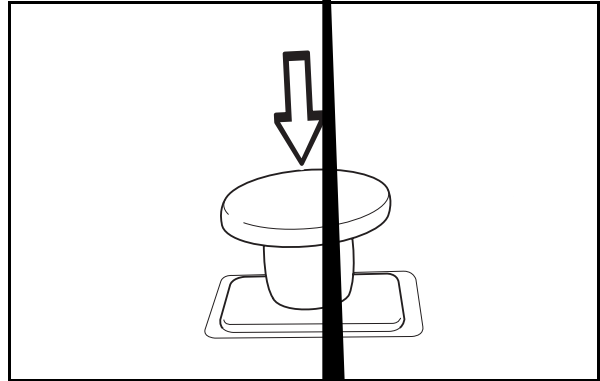

8011-668

Disengage the mower deck

2. Raise the mower deck by depressing the pedal forward to the transport position.
3. When the machine is standing still, activate the parking brake by pulling the lever backward.
4. Move the throttle to the minimum position (tortoise symbol). Turn the ignition key to the stop position. Never use choke to stop engine.
5. Move the steering controls outward.
6. Remove key. Always remove key when leaving the mower to prevent unauthorized use.

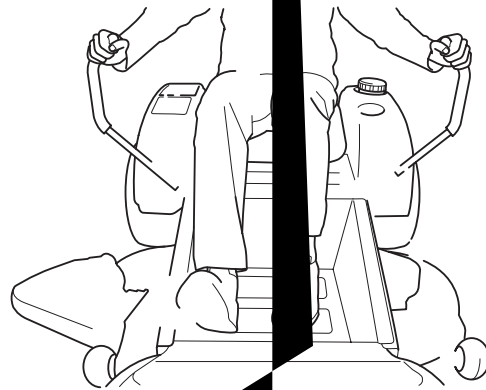

OPERATION

Moving by Hand



WARNING!

No adjustments or maintenance to be carried out unless:

- the engine stopped,
- the ignition key has been removed,
- the parking brake is on.

When pushing or pulling the mower, be sure to engage the IZT (Integrated Zeroturn Transaxle) bypass linkages. The IZT bypass linkages are located on the rear of the frame, below the rear engine guard.

- Raise the deck into the highest cutting position.
- Pull the IZT bypass linkages out and into the slots and release so that it is held in the bypass position.
- To reengage the IZT's to drive, reverse the above procedure.

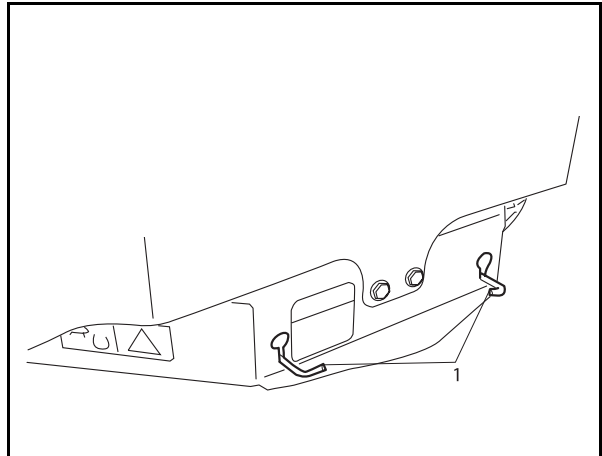

CZ10-2

1. IZT Bypass linkage

Bypass linkages

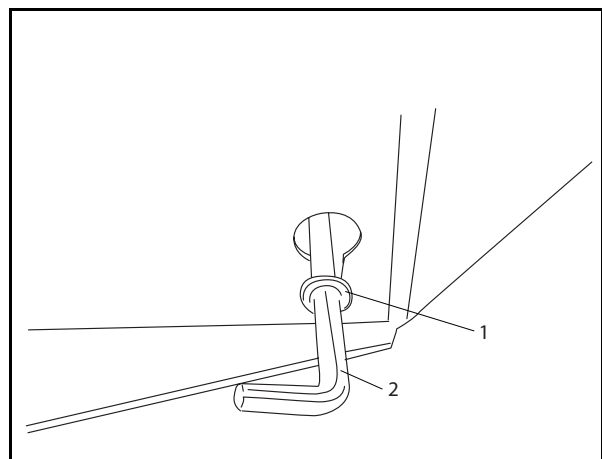

CZ12

1. Head outside of rear deck

2. IZT Bypass linkage in bypass position

Bypass position

MAINTENANCE

Maintenance

Maintenance Schedule

The following is a list of maintenance procedures that must be performed on the machine. For those points not described in this manual, visit an authorized service workshop. An annual service carried out by an authorized service workshop is recommended to maintain your machine in the best possible condition and to ensure safe operation.

Read "Maintenance" in the Safety Instructions section.

¹⁾ First change after 5-8 hours. When operating with a heavy load or at high ambient temperatures, replace every 50 hours. ²⁾ In dusty conditions, cleaning and replacement are required more often. ³⁾ For daily use, the machine should be lubricated twice weekly. ⁴⁾ Performed by authorized service workshop.

● = Described in this manual

○ = Not described in this manual

Maintenance	Page	Daily maintenance		Weekly maintenance	At least once each year	Maintenance interval in hours			
		Before	After			25	50	100	300
Check the parking brake	53	●							
Check the engine's oil level (every refueling)	57	●							
Check the safety system	39	●							
Check for fuel and oil leakages	-	○							
Check/clean the engine's cooling air intake	40		●						
Check the mower deck	48		●						
Check hardware (screws, nuts, etc.)	52		●						
Clean under the mower deck	52		●						
Start the engine and blades, listen for unusual sounds	-		○						
Check for damage	-		○						
Thoroughly clean around the engine	-		○						
Clean around belts, belt pulleys, etc.	-		○						
Check the tire pressures	44					●			
Check battery	37					●			
Sharpen/Replace mower blades	48					●			
Check the fuel pump's air filter ²⁾	44					●			
Clean the engine's cooling air intake ²⁾	40				●	●			
Clean the air cleaner's pre-filter ²⁾ (foam)	41				●	●			
Clean the air cleaner's filter cartridge ²⁾ (paper filter)	41				●		●		
Check/adjust the parking brake	-				○		○		
Inspect muffler/Spark arrester	-				○		○		

MAINTENANCE

Maintenance	Page	Daily maintenance		Weekly maintenance	At least once each year	Maintenance interval in hours			
		Before	After			25	50	100	300
Check/adjust throttle and choke cables	40				●			●	
Check the condition of belts, belt pulleys, etc.	45				●			●	
Change the engine oil ¹⁾	56				●		●		
Replace the engine oil filter	58				●			●	
Clean/replace the spark plugs	38				●			●	
Replace the fuel filter	44				●			●	
Replace the air filter (paper filter) ²⁾	43				●			●	
Check the caster wheels (every 200 hours)	52							●	
Clean the cooling fins ²⁾	-				○			○	
Replace the air cleaner's pre-filter ²⁾ (foam)	41				●				●
Check/adjust the mower deck	50				●				●
Check the engine valve clearance ⁴⁾	-				○				○
Perform the 300-hour service ⁴⁾	79				○				○
Lubricate according to Lubrication Schedule	54				●	●	●	●	●
Check transaxle oil at reservoir				●					
Change transaxle oil & filter (200 hours)					●				

¹⁾ First change after 5-8 hours. When operating with a heavy load or at high ambient temperatures, replace every 50 hours. ²⁾ In dusty conditions, cleaning and replacement are required more often. ³⁾ For daily use, the machine should be lubricated twice weekly. ⁴⁾ Performed by authorized service workshop.

● = Described in this manual

○ = Not described in this manual



WARNING!

Before performing any service or adjustment checklist:

- Engage the parking brake.
- Place the Blade-switch in the disengaged position.
- Turn the ignition switch to "OFF" position and remove the key.
- Make sure the blades and all moving parts have completely stopped.
- Disconnect the spark plug wire from all spark plugs and place the wire where it cannot come in contact with the plug.

MAINTENANCE

Battery

Your mower is equipped with a maintenance free battery and does not need servicing. However, periodic charging of the battery with an automotive type battery charger will extend its life.

- Keep battery and terminals clean.
- Keep battery bolts tight.
- Recharge at 6-10 amperes for 1 hour

To clean battery and terminals

Corrosion and dirt on the battery and terminals can cause the battery to “leak” power.

1. Open the terminal access doors.
2. Disconnect BLACK battery cable first, then the RED battery cable and remove the battery from the machine.
3. Rinse the battery with plain water and dry.
4. Clean terminals and battery cable ends with wire brush until shiny.
5. Coat terminals with grease or petroleum jelly
6. Reinstall battery.

Replacing battery

1. Lift Seat and rotate forward.
2. Open terminal access doors.
3. Using two 1/2" wrenches disconnect BLACK battery cable then RED battery cable.
4. Using 7/16" wrench, remove terminal guard.
5. Carefully remove the battery from the mower.
6. Install new battery with terminals in the same position as the old battery.
7. Reinstall terminal guard.
8. First connect RED battery cable to positive (+) battery terminal with hex bolt and hex nut.



Always use protective glasses when handling the battery.

IMPORTANT INFORMATION

Do not attempt to open or remove caps or covers. Adding or checking level of electrolyte is not necessary.

Always use two wrenches for the terminal screws



WARNING!

Do not short battery terminals by allowing a wrench or any other object to contact both terminals at the same time. Before connecting battery, remove metal bracelets, wristwatch bands, rings, etc. Positive terminal must be connected first to prevent sparks from accidental grounding.

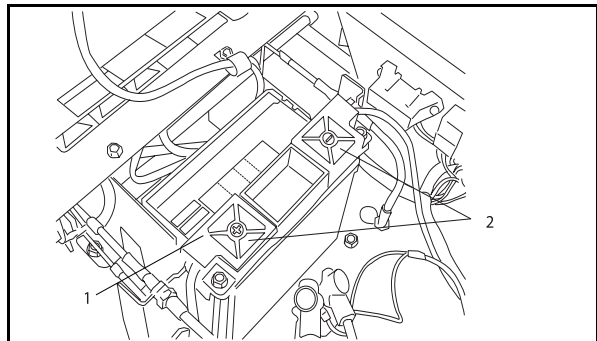

CZ-22

1. Terminal guard
2. Terminal access doors

Battery installation

MAINTENANCE

9. Connect BLACK grounding cable to negative (-) battery terminal with remaining hex bolt and hex nut.
10. Tighten securely.
11. Close terminal access doors.
12. Lower seat.

Ignition System

The engine is equipped with an electronic ignition system. Only the spark plugs require maintenance.

For recommended spark plugs, see Technical Data.

1. Remove the ignition cable boot and clean around the spark plug.
2. Remove the spark plug with a spark plug socket wrench.
3. Check the spark plug. Replace the spark plug if fouled, the electrodes are burned and if the insulation is cracked or damaged. Clean the spark plug with a steel brush if it is to be reused.
4. Measure the electrode gap with a gapping tool. The gap should be .030" (0.75 mm). Adjust as necessary by bending the side electrode.
5. Reinsert the spark plug, turning by hand to avoid damaging the threads.
6. After the spark plug is seated, tighten it using a spark plug wrench so that the washer is compressed. A used spark plug should be turned 1/8 of a turn from the seated position. A new spark plug should be turned 1/4 a turn from the seated position.
7. Replace the ignition cable.

IMPORTANT INFORMATION

Fitting the wrong spark plug type can damage the engine.

Inadequately tightened spark plugs can cause overheating and damage the engine. Tightening the spark plugs too hard can damage the threads in the cylinder head.

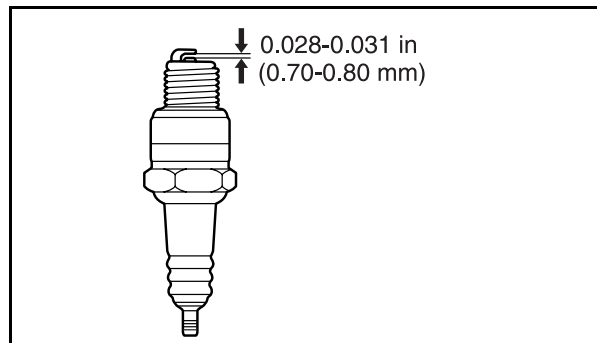

8011-054

Measure the electrode gap

MAINTENANCE

Checking the Safety System

The machine is equipped with a safety system that prevents starting or driving under the following conditions.

The engine can only be started when:

1. The mower deck is disengaged.
2. The steering controls are in the outer, locked neutral position.
3. The driver is sitting in the driver's seat.
4. The parking brake is on.

Make daily inspections to ensure that the safety system works by attempting to start the engine when one of the conditions is not met. Change the conditions and try again.

MAINTENANCE

Checking the Engine's Cooling Air Intake

Check that the engine's cooling air intake is free from leaves, grass, and dirt. If the cooling air intake is clogged, engine cooling deteriorates, which can lead to engine damage.

The cooling air intakes rotates when the engine is running. Mind your fingers.

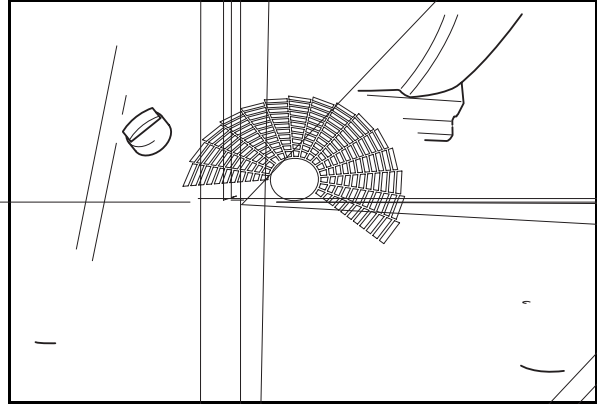

Checking and Adjusting the Throttle Cable

Check that the engine responds to throttle increases and that a good engine speed is attained at full throttle. If doubts arise, contact the service workshop. If adjustments are necessary, they can be made as follows for the lower cable:

1. Loosen the clamping screw for the cable's outer casing and move the throttle to the full throttle position.
2. Check that the throttle cable is mounted in the correct hole in the lower lever, see illustration.
3. Push the throttle cable's outer casing as far to the right as possible and tighten the clamping screw.

Checking and Adjusting the Choke Cable

If the engine produces black smoke or is difficult to start, this can be because the choke cable is incorrectly adjusted (upper cable). If doubts arise, contact the service workshop. If adjustments are necessary, they can be made as follows:

1. Loosen the clamping screw for the cable's outer casing and push the choke control fully in.
2. Check that the choke cable is mounted in the upper lever, see illustration. Push the choke cable's outer casing as far to the left as possible and tighten the clamping screw.

MAINTENANCE

Replacing the Air Filter - Briggs & Stratton Engine

Standard air filter

If the engine seems weak or runs unevenly, the air filter may be clogged. If run with a dirty air filter, the spark plugs can become fouled disrupting operation.

For this reason, it is important to replace the air filter regularly (see the heading Maintenance Schedule for the proper service interval).

Cleaning/replacing the air filter is carried out as follows:



WARNING!

The engine and the exhaust system, become very hot during operation. Risk for burns if touched.

Allow engine and exhaust system to cool at least two (2) minutes.

1. Remove the air filter cowl
2. Remove the filter cartridge.
3. Remove the foam filter (pre-cleaner). Clean the foam filter with liquid detergent and water. Squeeze dry in a clean cloth. Saturate with engine oil and squeeze it inside a clean absorbent cloth.
4. Tap the paper filter against a fixed surface to remove dust. If the paper filter is still dirty, it must be replaced.

IMPORTANT INFORMATION

Do not use compressed air to clean the air filter.

Do not wash the paper filter.

Do not oil the paper filter.

5. Wipe clean the inside of air filter housing.
6. Refit the foam filter (pre filter).
7. Mount the filter in the air filter housing.
8. Replace the cowl over the air filter housing.

IMPORTANT INFORMATION

Please see the manual of the engine manufacturer for any additional instructions, including safety instructions.

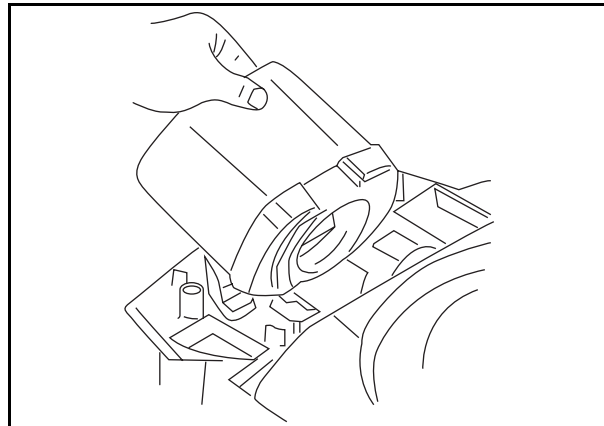

Remove filter

8019-014

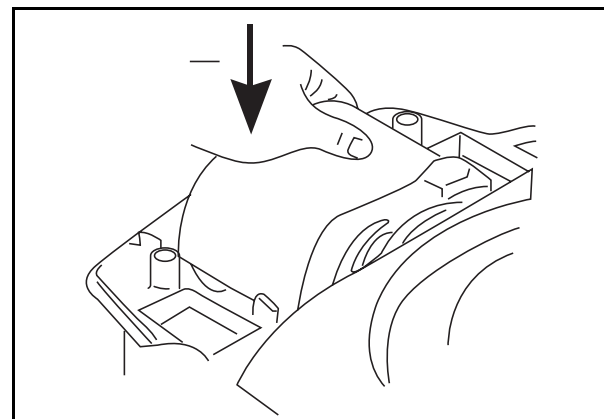

Install filter

8019-015

MAINTENANCE

Replacing Heavy Duty Air Filter (Kohler)

If the engine seems weak or runs unevenly and the dust load indicator has turned red the air filter may be clogged. If run with a clogged air filter, disruption of operation can occur.

Cleaning/replacing the air filter is carried out as follows:



WARNING!

The engine and the exhaust system, become very hot during operation. Risk for burns if touched.

Allow engine and exhaust system to cool at least two (2) minutes.

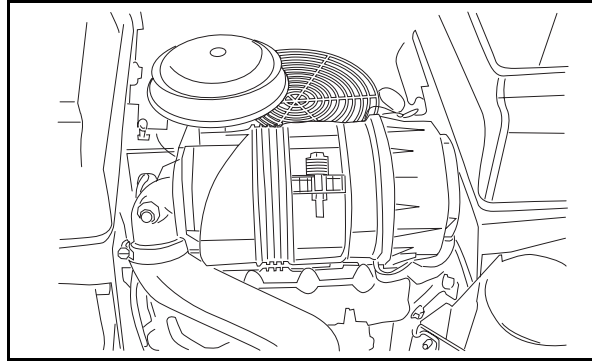

Heavy Duty Filter

8019-016

1. Unfasten the two metal clamps on the sides of the air filter cover. Remove the air filter cover.
2. Remove the paper filter. Lightly brush or use mild air pressure to clean

IMPORTANT INFORMATION

Do not use compressed air to clean the air filter.

Do not wash the paper filter.

Do not oil the paper filter.

Do not tap filter to clean this could cause damage to the sealing.

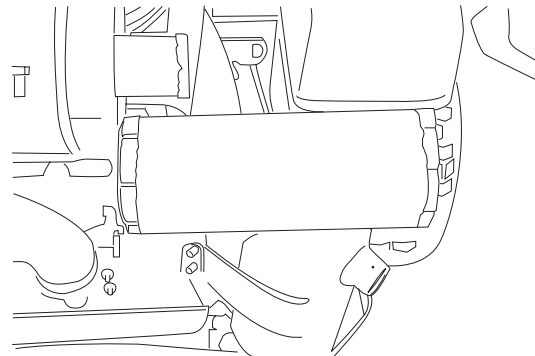

Outer element

8019-018

3. Only remove and replace safety element after the paper filter has been replaced 3 or 4 times.
4. Refit the air filter as follows:
Check that the seal on the bottom of the paper filter is whole.
Mount the safety element in the air filter housing.
5. Place the paper filter over the safety element.
6. Replace the cover over the air filter housing. Fasten the two metal clamps making sure the cover is snapped into position.
7. Push top of dust load indicator to reset it.

Replacing the Air Filter (Honda)

Standard air filter

If the engine seems weak or runs unevenly, the air filter may be clogged. If run with a dirty air filter, the spark plugs can become fouled, disrupting operation.

It is important to replace the air filter regularly (see the heading Maintenance Schedule for the proper service interval).

To clean or replace the air filter:



WARNING!

The engine and the exhaust system, become very hot during operation. Risk for burns if touched. Allow engine and exhaust system to cool at least two (2) minutes.

1. Loosen the fastener and the two top inner screws. Remove the air cleaner cover.
2. Remove the paper filter.
3. Remove the foam rubber pre-filter and clean or replace as necessary. To clean, wash with warm water using a mild detergent. Squeeze out excess water and allow to air dry. After drying, dip the filter in clean engine oil and squeeze out excess.
4. Tap the paper filter against a fixed surface to remove dust. If the paper filter is still dirty, it must be replaced.

IMPORTANT INFORMATION

Do not use compressed air to clean the air filter.

Do not wash the paper filter.

Do not oil the paper filter.

5. Refit the air filter as follows:

Place the foam prefilter into the air cleaner compartment. Replace the gaskets.

Mount the paper filter in the air filter housing and tighten the screws and wing nuts.

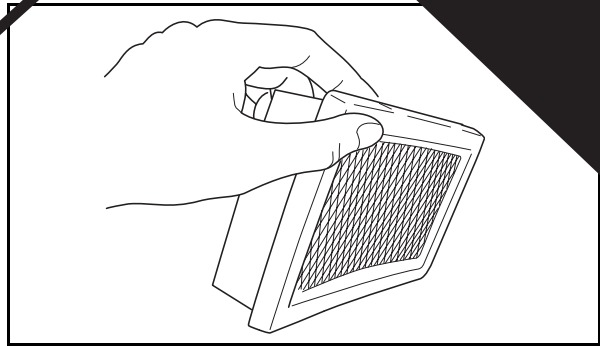
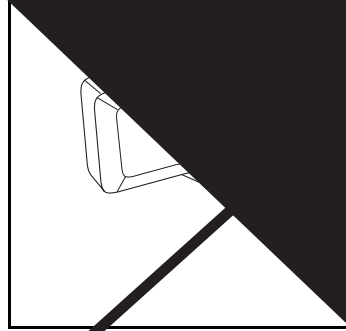

8057-728

Remove the paper filter

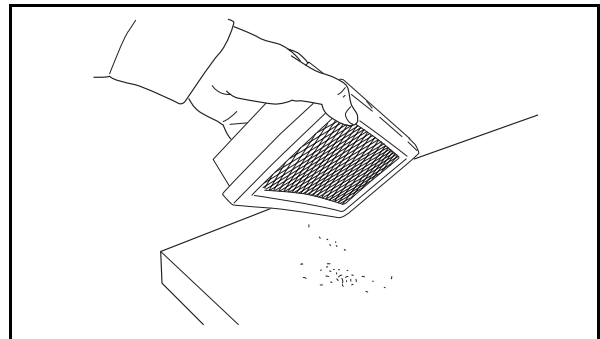

8057-182

Remove dust

MAINTENANCE

Replacing the Fuel Filter

Replace the line-mounted fuel filter every 100 hours (once per season) or more regularly if it is clogged.

Replace the filter as follows:

1. Move the hose clamps away from the filter. Use flat-nosed pliers.
2. Pull the filter loose from the hose ends.
3. Push the new filter into the hose ends. Position the filter with the "FLOW" arrow pointing up toward the fuel pump. If necessary, a soap solution can be applied to the filter ends to ease mounting.
4. Move the hose clamps back toward the filter.

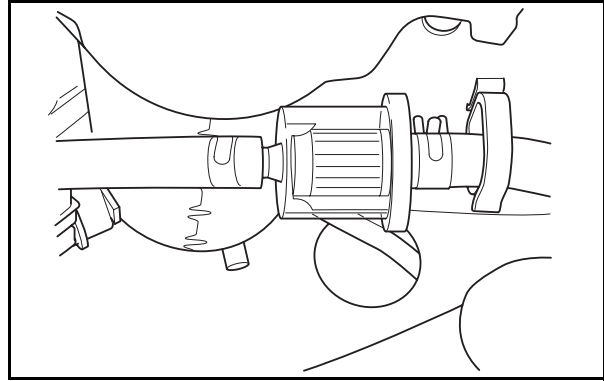

8011-729

Fuel filter

Checking the Fuel Pump's Air Filter

Regularly check that the fuel pump's air filter is free from dirt.

Remove the screws and open the pump, no hoses need be removed.

The filter can be cleaned with a brush if necessary.

Replace the filter on the console.

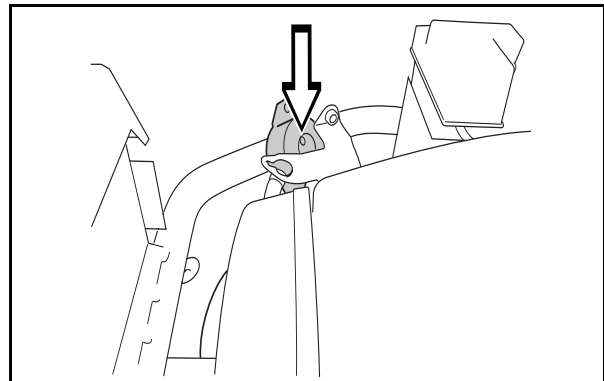

8009-147

The fuel pump's air filter

Checking Tire Pressures

All four tires shall have a pressure of 15 psi / 103 kPa / 1 bar.

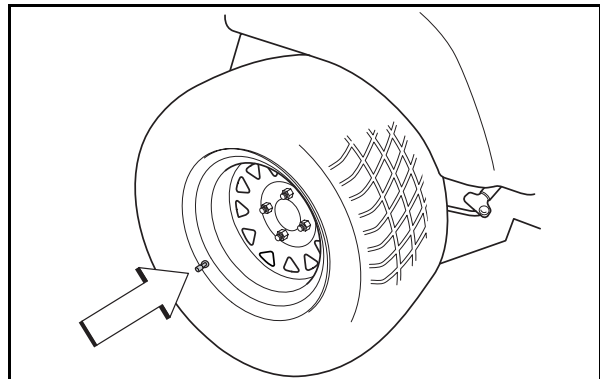

8011-564

Tire pressures

MAINTENANCE

Checking the Parking Brake

Visually check that no damage is found on the lever, links, or switch belonging to the parking brake. Perform a stand-still test and check that there is sufficient braking action.

To adjust the parking brake, contact the Husqvarna service workshop.



WARNING!

Faulty adjustment result in reduced braking ability and can cause an accident.

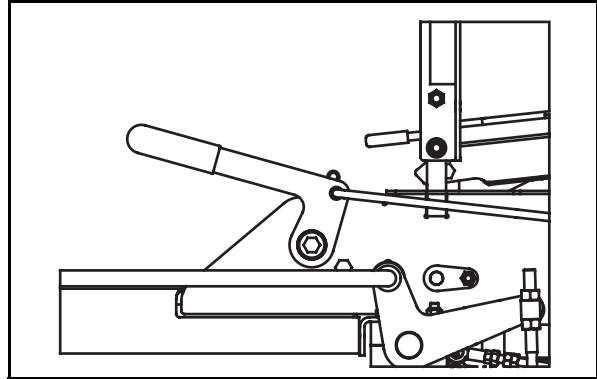

The parking brake in the disengaged position

Checking the V-belts

Check every 100 hours of operation. Check for severe cracking and large nicks.

NOTE: The belt will show some small cracks in normal operation.

The belts are not adjustable. Replace belts if they begin to slip from wear.

Deck belt

To replace deck belt

Deck belt removal.

- Park on a level surface. Apply park brake.
- Lower the deck into the lowest cutting position.
- Using a ratchet with a 9/16" socket on the spring idler bolt to relieve the tension on the belt.
- Remove screws from both the left and right belt shields, and remove shields.
- Remove any dirt or grass that may have accumulated around the cutter housings and entire deck surface.
- Carefully roll the belt over the top of the cutter housing pulleys.
- Remove the belt from around the electric clutch on the engine shaft.
- The belt can now be removed.

IMPORTANT INFORMATION

The machine must be absolutely standing still when applying the parking brake.

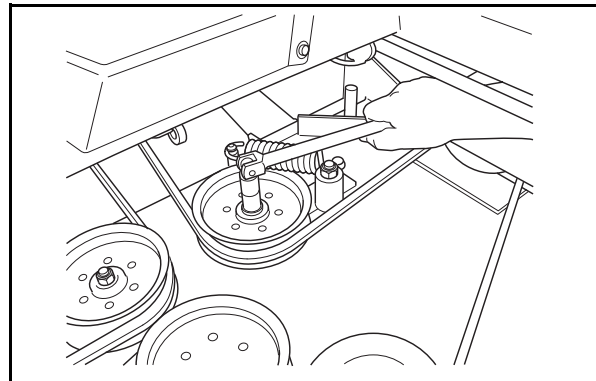

Slackening the belt tensioner

MAINTENANCE

Deck belt installation

NOTE: For ease in installing the deck belt, refer to the routing decal on the front edge of the deck.

- Wrap the deck belt around the electric clutch that is located on the engine shaft.
- Push the rest of the belt through the IZT(Integrated Zereturn Transaxle) support and up onto the deck.
- Starting on the right hand side of the deck, wrap the belt around the large right side idler, right cutter housing pulley, small center idler, center pulley, left side pulley and then around the large left side idler.
- The belt will be loose at this point.
- Using a ratchet with a 9/16" socket on the spring idler bolt to relieve the tension on the belt. See decal on the top of deck for belt routing information.
- After installation is complete check the belt for twists.

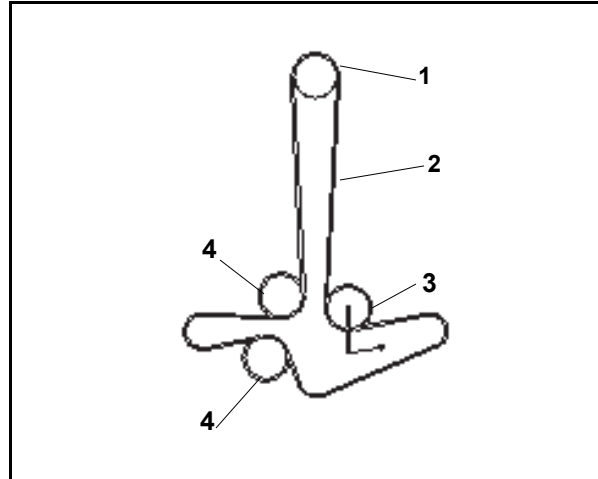

8050-158

1. Clutch pulley
 2. Deck belt
 3. Spring idler pulley
 4. Fixed idler pulley
- Belt routing, deck belt*

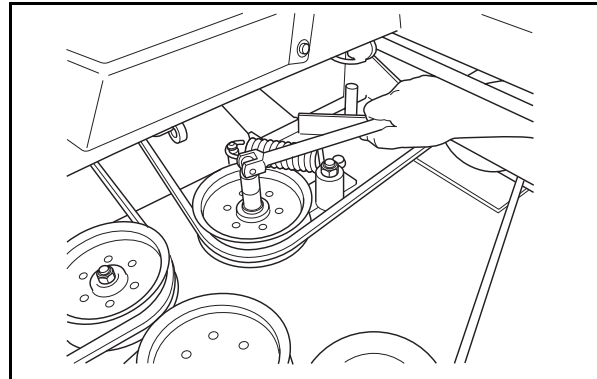

8011-622

Slackening the belt tensioner

MAINTENANCE

IZT belt

To replace IZT (Integrated Zereturn Transaxle) belt

Park the mower on a level surface. Engage the park brake.

IZT belt removal

NOTE: Be careful not to damage the fan blades on the IZT as this can affect cooling or damage the IZT

- Remove the deck belt (see to replace deck belt in this section of the manual).
- Create slack in the belt by either removing the spring on the pump idler arm or inserting 1/2" breaker bar into the square hole on the spring loaded idler. Rotate arm to release belt tension.
- The belt should now be able to be removed from the engine pulley and IZT pulleys.

Belt installation

- Wrap the IZT belt around the IZT pulleys.
- Route the belt around the inside of the idler pulley.
- Now you can wrap the belt around the engine pulley.
- Reattach the spring on the pump idler arm if previously disconnected.
- Reinstall the deck belt onto the electric clutch pulley (see to replace deck belt in this section of the manual).

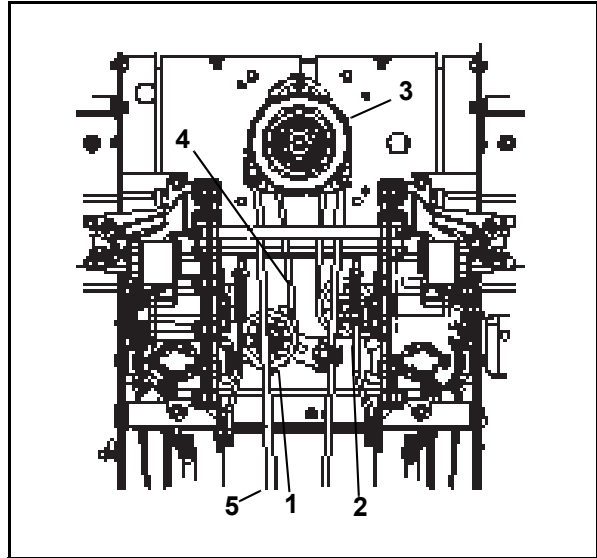

8050-156

1. Spring loaded idler pulley
2. Fixed idler pulley
3. Electric clutch
4. IZT belt
5. Deck belt

IZT belt

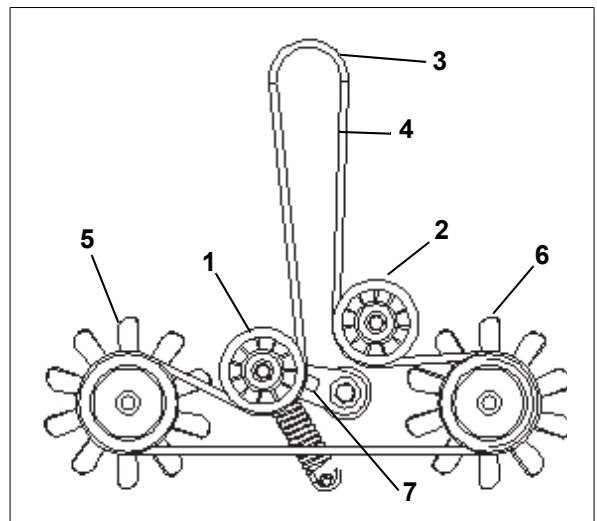

8050-157

1. Spring loaded idler pulley
2. Fixed idler pulley
3. Engine
4. IZT belt
5. Left drive pulley
6. Right drive pulley
7. Square hole

IZT belt routing

MAINTENANCE

Checking the Blades

In order to attain the best mowing effect, it is important that the blades are well sharpened and not damaged.

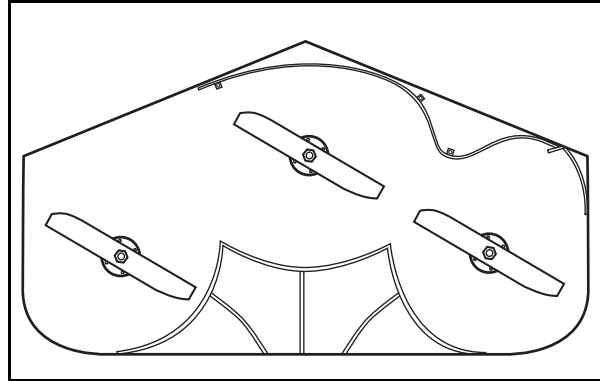
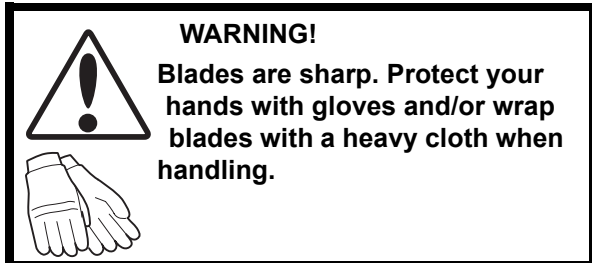

8011-604

Check the blades

Bent or cracked blades or blades with large nicks should be replaced.

Damaged blades should be replaced when hitting obstacles that result in a breakdown. Let the service workshop decide whether the blade can be repaired/ground or must be replaced.

Balance the blades after sharpening.

Check the blade mounts.

IMPORTANT INFORMATION

The sharpening of blades should be carried out by an authorized service workshop.

Damaged blades should be replaced when hitting obstacles that result in a breakdown. Let the service workshop decide whether the blade can be repaired/ground or must be replaced.

MAINTENANCE

Blade replacement:

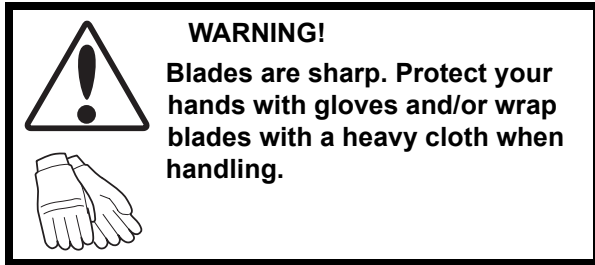

- Remove blade bolt by turning counterclockwise.

IMPORTANT INFORMATION

To ensure proper assembly, center hole in blade must align with star on cutter housing.

- Install new or re-sharpened blade with stamped "GRASS SIDE" facing towards ground/grass (down) or "THIS SIDE UP" facing deck and cutter housing.
- Install and tighten blade bolt securely.
Torque blade bolt to 45-55 ft/lbs (60-75 Nm).

IMPORTANT INFORMATION

Special blade bolt is heat treated.
Replace with a Husqvarna bolt if required.
Do not use lower grade hardware than specified.

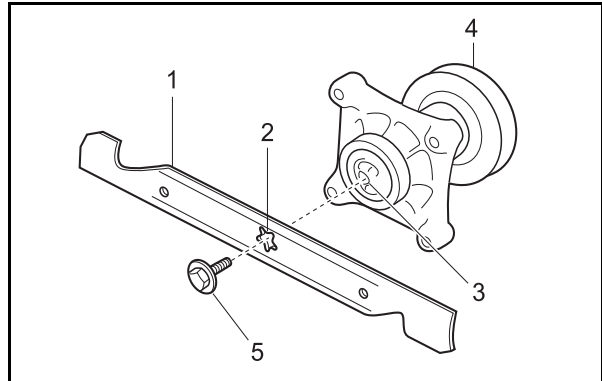

8011-671

1. Blade
2. Center hole
3. Star
4. Cutter housing
5. Blade bolt (special)

Blade attachment, principal

MAINTENANCE

Adjusting the Mower Deck



WARNING!

Before performing any service or adjustment checklist:

1. Engage the parking brake.
2. Place the Blade switch in the disengaged position.
3. Turn ignition switch to "OFF" position and remove the key.
4. Make sure the blades and all moving parts have completely stopped.
5. Disconnect the spark plug wire from all spark plugs and place the wire where it cannot come in contact with the plug.

Check the tire pressure before adjustment of the mower deck, refer to page 44.

Faulty mower deck adjustment will cause uneven mowing result.

Leveling

1. Position the mower on a level, preferably concrete, surface.
2. Check the pressure in all four tires. See "Technical Data" on page 66.
3. Raise the mower on lengths of 2" x 4" placed edgewise under the cutting deck from front to rear (see diagram).
4. Lower the deck onto the 2" x 4"s. The rear of the deck is approximately 1/4" deeper than the front. This gives the deck a proper pitch front to back when lowered onto the 2" x 4" guides.
5. Set cutting height to 4".
6. Adjust the four lower chain bolts so that they are centered in the oblong slots.
7. Move the lifting lever and check that all the chains are equally tensioned. If they are not, adjust the appropriate lower chain bolt in its slot.



WARNING!

Blades are sharp. Protect your hands with gloves and/or wrap blades with a heavy cloth when handling.

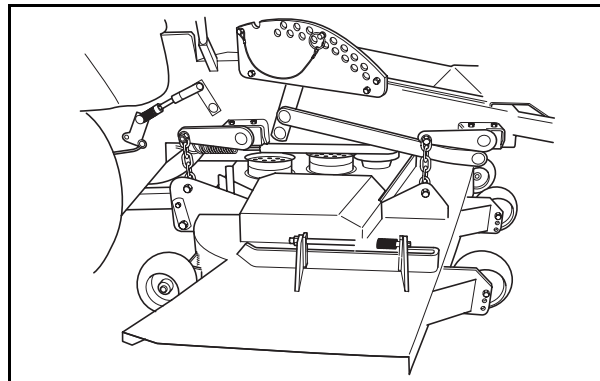

8011-601

Leveling the mower deck

Adjusting Cutting Height

1. Raise and secure the deck height lever to the transport position (4 1/2").
2. Position blade tip so it is straight forward.
3. Measure from the cutting edge of the blades to a flat level surface. The distance should be 4 1/2" (114 mm).
4. Drop and secure the lever at (for example) the 2" cutting height. Measure as above. The distance should be 2" (50 mm).

MAINTENANCE

To adjust anti-scalp rollers

Anti-scalp rollers are properly adjusted when they are just slightly off of the ground when the deck is at the desired cutting height in the operating position. Anti-scalp rollers then keep the deck in the proper position to help prevent scalping in most terrain conditions.

IMPORTANT INFORMATION

Adjust Anti-scalp rollers with the mower on a flat level surface.

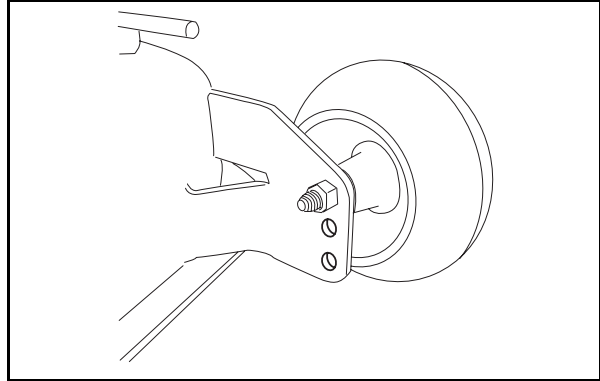

CZ-9

Anti-scalp roller

1. Adjust the deck to the desired cutting height (see "TO ADJUST DECK CUTTING HEIGHT" in the operation section of this manual).
2. Using a 3/4" wrench and a 9/16" wrench, remove the nut and shoulder bolt from the anti-scalp roller.
3. Lower the anti-scalp roller to the ground, and raise it up to the next highest hole.
4. Replace and tighten the nut and shoulder bolt.
5. Be sure to adjust all of the anti-scalp rollers to the same position.
6. Be sure to readjust the anti-scalp rollers if the cutting height is changed.

IMPORTANT INFORMATION

The anti-scalp rollers must not be used for gauge wheels or the roller and deck may be damaged.

Cleaning

Regular cleaning under the mower deck extends the machine's life. Clean the machine (and engine, if cooled), before

Do not spray water on the deck. Use compressed air on the side of mower deck and underside of the deck. Do not use high pressure. Do not use a steam cleaner. Avoid electrical components w

Check every 200 hours. If wheels do not rotate freely. If wheels do not rotate freely, take the unit to your dealer.

MAINTENANCE

Parking brake

To adjust parking brake

Jack up unit and support properly with jack stands. Allow clearance to work at rear transaxles. Before making any adjustments:

Set park brake.

Measure the distance between the rod swivel pin and the brake arm washer. With the brake engaged, there should be a gap of 1/8" to 1/2" (3 mm to 13 mm) between the swivel pin and the brake arm washer.

If measurement is out of range adjust as follows:

Disengage park brake lever. Remove retaining clip and remove brake arm by pulling horizontally from the IZT splined shaft.

Rotate brake arm on spline "rearward" to increase brake tension. Rotate the brake arm one spline "forward" to decrease brake arm tension.

Reinstall the retaining clip and recheck gap between rod swivel pin and brake rod washer. Repeat the procedure on the other IZT.

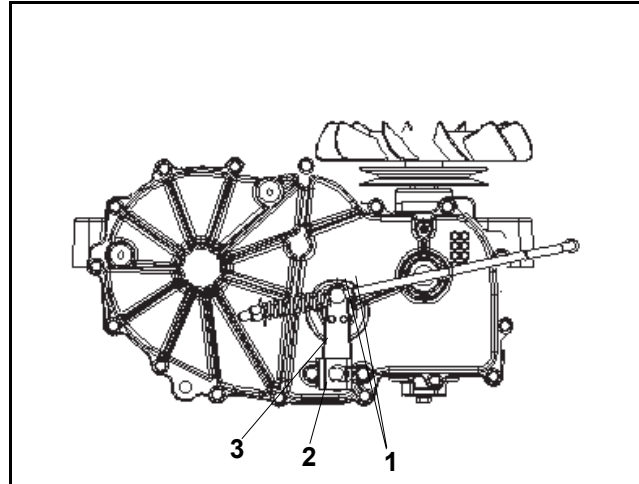

- 8050-160
1. Gap 1/8" to 1/2" between swivel and washer
 2. Retaining clip
 3. Brake arm

Park brake

Tracking adjustment

If the mower is not tracking straight, check the air pressure in both rear tires. Recommended air pressure is 15 psi (1 bar). If the unit will not track straight, follow the steps below. Tracking must be checked on a flat and level concrete or blacktop surface.

Mower is tracking to the right.

Increase the air pressure 2-3 psi (0.1-0.2 bar) in the right rear tire or decrease the air pressure 2/3 psi in the left rear tire.

Mower is tracking to the left.

Increase the air pressure 2-3 psi (0.1-0.2 bar) in the left rear tire or decrease the air pressure 2/3 psi in the right rear tire.

Recheck tracking and keep making adjustments with the tire pressure until the unit tracks straight.









DO NOT exceed maximum recommended tire pressure 24 psi (1.6 bar).

Record the tire pressure for future reference.

LUBRICATION

Lubrication

Lubrication Schedule

12/12	1/52	1/365			25h	50h	100h	200h	300h
					1  (2x)				
					2  (2x)				
					3 				
					4  (2x)				
					7  (2x)				
					6 				
					5 				
					* 				

*

General

Remove the ignition key to prevent unintentional movements during lubrication.

When lubricating with an oil can, it must be filled with engine oil.

When lubricating with grease, unless otherwise stated, use a high grade molybdenum disulfide grease.

For daily use, the machine should be lubricated twice weekly.

Wipe away excess grease after lubrication.

It is important to avoid getting lubricant on the belts or the drive surfaces on the belt pulleys. Should this happen, attempt to clean them with spirits. If the belt continues to slip after cleaning, it must be replaced. Gasoline or other petroleum products must not be used to clean belts.

LUBRICATION

Lubricating the Cables

If possible, grease both ends of the cables and move the controls to end stop positions when lubricating. Refit the rubber covers on the cables after lubrication. Cables with sheaths will bind if they are not lubricated regularly. If a cable binds, it can disrupt operation.

If a cable binds, remove the cable and hang it vertically. Lubricate it with light engine oil until the oil begins to escape from the bottom.

Tip: Fill a small plastic bag with oil and tape it so that it seals against the sheath and allow the cable to hang vertically from the bag overnight. If you do not succeed in lubricating the cable, it must be replaced.

Lubricating in Accordance with the Lubrication Schedule

1. Front Wheel Mount

Lubricate with a grease gun, one zerk for each wheel mount, until the grease is forced out.

Use only good quality bearing grease.

Grease from well-known brand names (petrochemical companies, etc.) usually maintains a good quality.

2. Front Wheel Bearings

Lubricate with a grease gun, one zerk for each set of wheel bearings, until the grease is forced out.

Use only good quality bearing grease.

3. Deck spindle

Lower the cutting deck completely.

If you use grease gun without rubber hose, the foot plate must be removed.

Lubricate with a grease gun, one zerk, 2-3 strokes.

Use only good quality bearing grease.

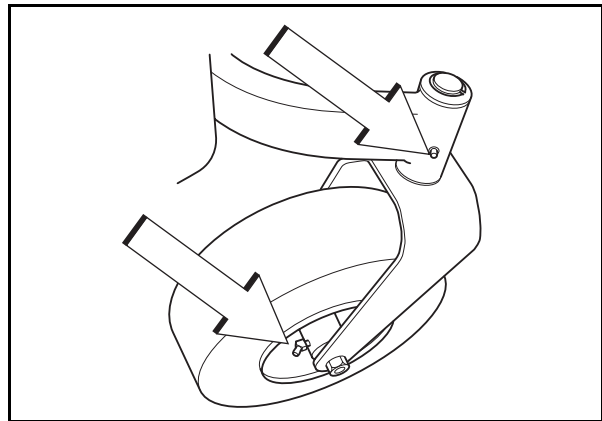

8011-731

Lubricating the front wheels

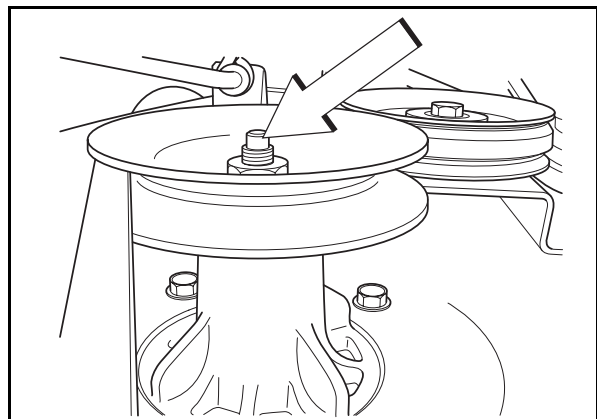

8011-732

Deck spindle

IMPORTANT INFORMATION

Use minimal lubrication and remove excess lubricant so that it does not come into contact with belts or belt pulley drive surfaces.

LUBRICATION

4. Deck outer spindle

Lubricate using a grease gun, one zerk, each side 2-3 strokes.

Use only good quality bearing grease.

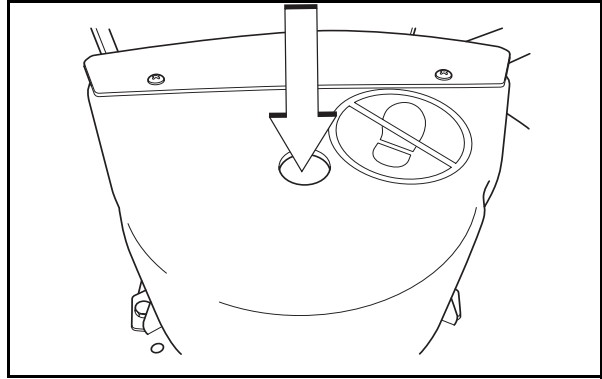

8011-733

Deck outer spindle

5. Engine Oil

Changing the Engine Oil

The engine oil should be changed for the first time after 5-8 hours of operation. Thereafter, it should be changed every 50 hours.

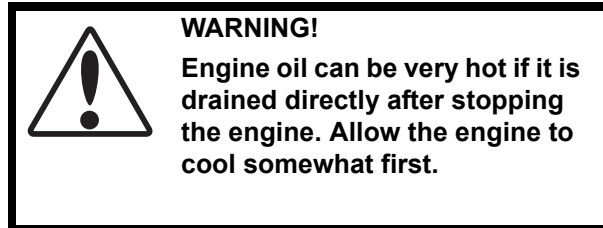

WARNING!

Engine oil can be very hot if it is drained directly after stopping the engine. Allow the engine to cool somewhat first.

IMPORTANT INFORMATION

Used engine oil is a health hazard and must not be disposed of on the ground or in nature; it should always be disposed of at a workshop or appropriate disposal location.

Avoid skin contact; wash with soap and water in case of spills.

1. Place the machine on a flat surface.
2. Place a container under the engine where the hose from the oil drain valve exits.
3. Remove the dipstick and open the drain valve.
4. Allow the oil to run out into the container.
5. Then close the oil drain valve.
6. Replace the oil filter if necessary.
7. Fill with new engine oil in accordance with Checking the Oil Level.
8. Start the engine. Run it for a few seconds. Stop and re-check the oil level.

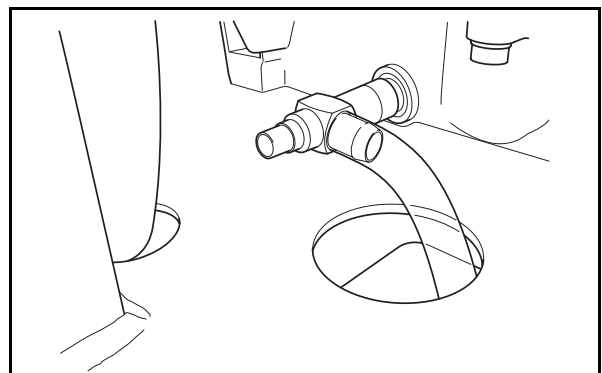

8011-730

Oil drain valve

LUBRICATION

Checking the Oil Level

Check the oil level in the engine when the machine is standing level and the engine is stopped.

Remove the dipstick, wipe it clean, and then replace it.

The dipstick should be screwed into place.

Take the dipstick out again and read the oil level.

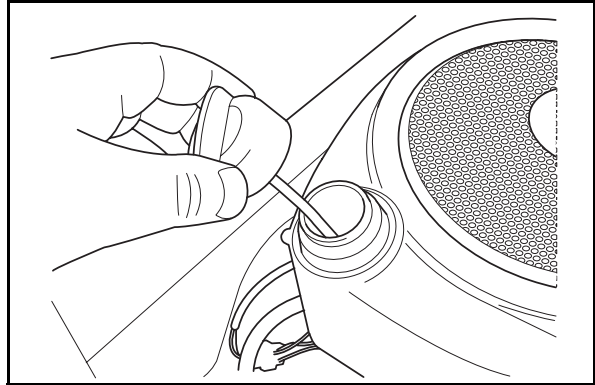

8011-500

Remove the dipstick

The oil level should lie between the markings on the dipstick. If the level is approaching the "ADD" mark, fill the oil to the "FULL" mark on the dipstick.

Never fill to above the "FULL" mark.

The oil is filled through the hole for the dipstick.

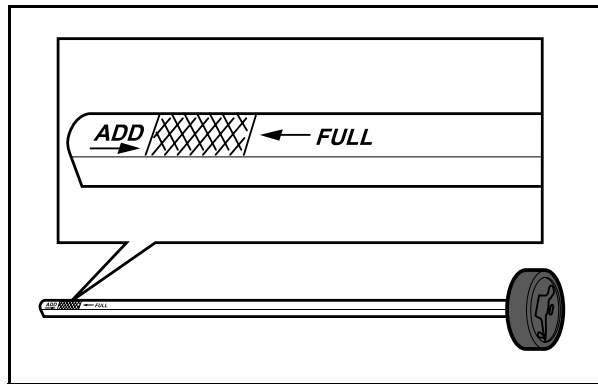

8009-159

The dipstick markings

API class SF, SG, SH, SJ or higher must be used. Synthetic oil SAE 5W-30 or 10W-30 is recommended at all temperatures. Mineral oil SAE 5W-30, 10W-30 can be used between -18 °C/0 °F and +5 °C/40 °F. At temperature above +5 °C/40 °F single grade SAE 30 must be used.

The engine holds 0.88 qt (1.0 liters) of oil excluding the filter, including filter 2 qt (1.9 liters).

LUBRICATION

6. Changing the Engine Oil Filter

1. Drain the engine oil in accordance with the work description under the heading Engine Oil/Change Engine Oil.
2. Remove the oil filter. If necessary, use a filter remover.
3. Wipe new, clean engine oil onto the seal for the new filter.
4. Mount the filter by hand with + 3/4 turn.
5. Run the engine warm, then check that there are no leaks around the oil filter seal.
6. Check the oil level in the engine, fill if necessary. The oil filter holds 0.1 qt (0.1 liters) of oil.

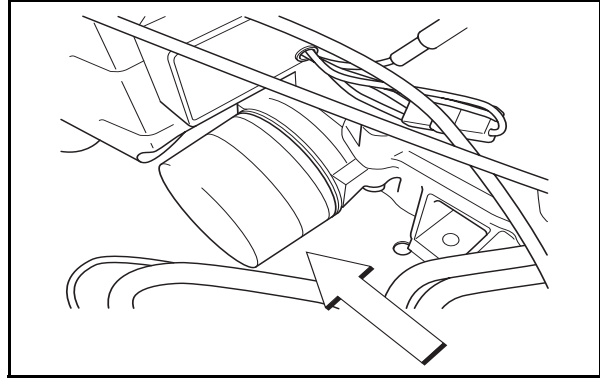

8011-734

Changing the oil filter

*Transaxle (Transmission) Fluid Change

This transaxle is designed with an external filter for ease of maintenance. To ensure constant fluid quality levels and longer life an oil filter change interval of every 200 hours is recommended.

The following procedure can be performed with the transaxles installed in the vehicle, and the vehicle on level ground. Apply the bypass valve for each transaxle and lock the vehicle parking brake.

1. Remove the three 1/4" filter guard screws and filter guard. Clean any loose debris from around the perimeter of the filter. See illustrations.
2. Place an oil drain pan (12" or more diameter and 8 qt. capacity is optimal) beneath the oil filter. Remove the oil filter from the transaxle.
3. After the oil has drained, wipe the filter base surface off and apply a film of new oil to the gasket of the new replacement filter.
4. Install the new filter by hand, turn 3/4 to one full turn after the filter gasket contacts the filter base surface.
5. Re-install the filter guard with the three 1/4" screws. Torque screws to 65 in/lbs. each.
6. Repeat steps on the opposite side of transaxle drive.

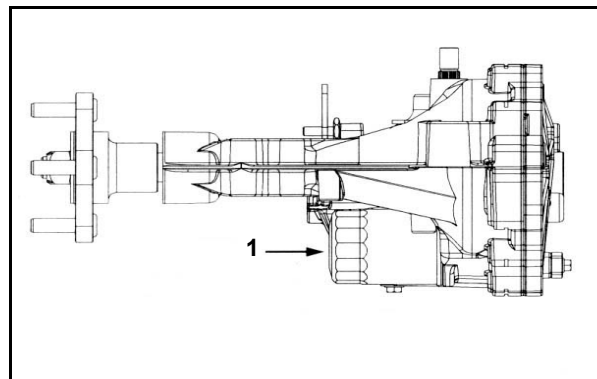

1. Filter (guard removed)

Changing the oil filter

8019-011

LUBRICATION

7. Drain old oil filters of all free flowing oil prior to disposal. Place used oil in appropriate containers and dispose of it in accordance with laws in your area.
8. Remove the top port plug (see illustration) from the left side and right side of the transaxles prior to filling with oil. This will allow the transaxles to vent during oil fill.
9. Remove the cap from the transaxles' expansion tank located on the vehicle frame.
10. Fill with 20W50 motor oil until oil just appears at the bottom of each transaxles' top port (approximately 2 quarts per transaxle, 4 quarts total). Install the top port lug into each transaxle as the oil level reaches this port.
11. Install and torque the top port plugs to 180 in./lbs.
12. Continue to fill the transaxles through the expansion tank until the "Full Cold" line is reached (this will take approximately 23 additional ounces).
13. Re-install the expansion tank cap by hand. Be careful to not overtighten.
14. Proceed to the purge procedure.

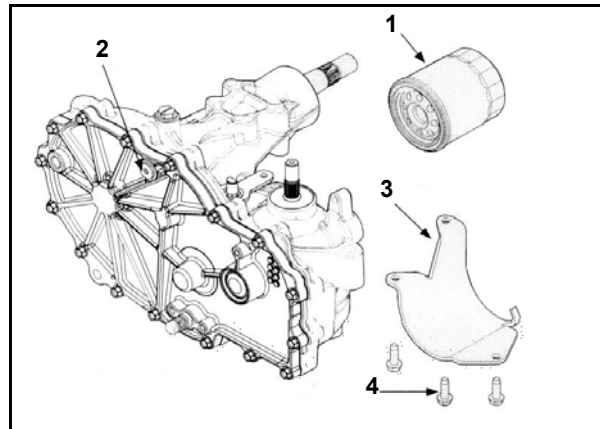

1. Filter
2. Top Port Plug
3. Filter Guard
4. Screws

Changing the oil filter

8019-010

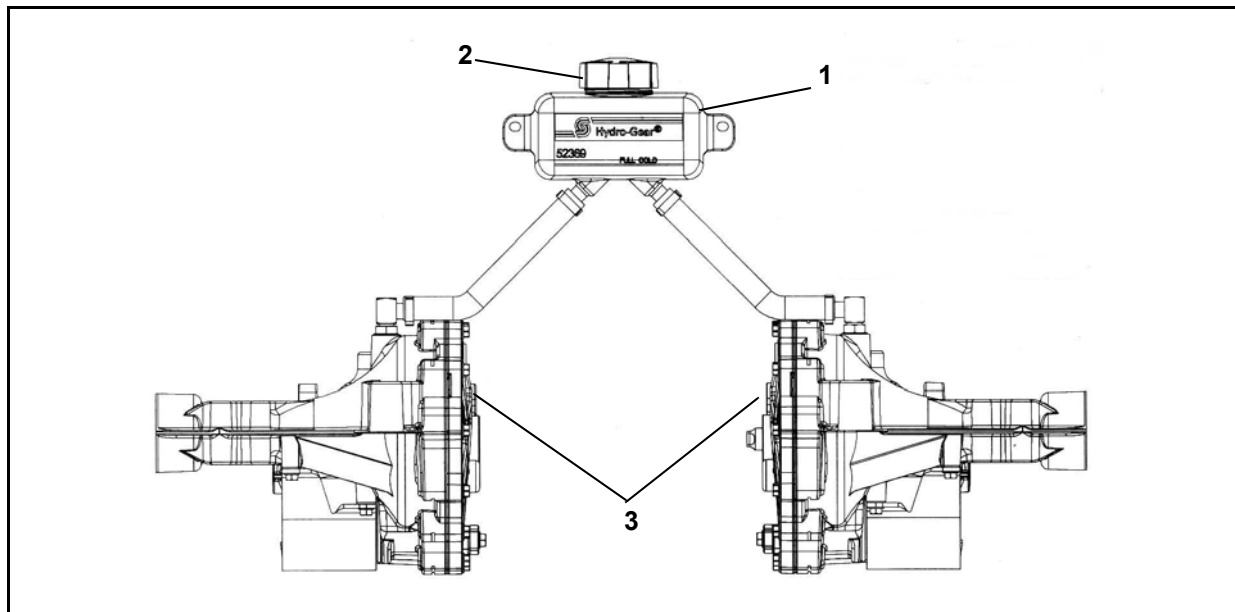

1. Expansion Tank
2. Cap
3. Transaxles

Expansion Tank

8019-012

LUBRICATION

Purging Procedures

Due to the effects air has on efficiency in hydrostatic drive applications, it is critical that it is purged from the system.

These purge procedures should be implemented any time a hydrostatic system has been opened to facilitate maintenance or any additional oil has been added to the system.

The resulting symptoms in hydrostatic systems may be:

1. Noisy operation.
2. Lack of power or drive after short term operation.
3. High operation temperature and excessive expansion of oil.

Before starting, make sure the transaxle is at the proper oil level. If it is not, fill to the specifications outlined earlier.

The following procedures are best performed with the vehicle drive wheels off the ground. Then repeated under normal operating conditions.

1. Disengage the brake if activated.
2. With the bypass valve open and the engine running at fast idle, slowly move the directional control in both forward and reverse directions (5 or 6 times). As air is purged from the unit, the oil level will drop.
3. With the bypass valve closed and the engine running, slowly move the directional control in both forward and reverse directions (5 to 6 times). Check the oil level, and add oil as required after stopping the engine.
4. It may be necessary to repeat Steps 2 and 3 until all the air is completely purged from the system. When the transaxle operates at normal noise levels and moves smoothly forward and reverse at normal speeds, then the transaxle is considered purged.
5. After the vehicle has been used two times, the oil level should be checked while the oil is cold and adjusted accordingly.

TROUBLE SHOOTING GUIDE

Trouble Shooting Guide

Problem**Cause**

The engine will not start.

- The blade switch is engaged.
- The steering controls are not locked in the neutral position.
- The driver is not sitting in the driver's seat.
- The parking brake is not activated.
- The battery is dead.
- Contamination in the carburetor or fuel line.
- The fuel supply is closed or the shut-off valve for the fuel tank is in the wrong position.
- Clogged fuel filter or fuel line.

The starter does not turn the engine over.

- Dead battery.
- Poor contacts on the battery terminal cable connections.
- Fuse blown.
- Ignition system faulty.
- Fault in the starter safety circuit.
See Checking the Safety System in the "Maintenance Section,"

The engine runs rough.

- Faulty carburetor.
- The choke control is pulled out with a warm engine.
- Defective valves.
- Defective piston, cylinder, piston ring, or cylinder head seal.
- The cylinder head bolts are loose.
- Clogged fuel filter or jet.
- Clogged ventilation valve on the fuel cap.
- Fuel tank nearly empty.
- Defective spark plugs.
- The spark plugs are loose.
- Defective ignition cable.
- Defective spark plug electrode.
- Defective spark plug connection.
- Rich fuel mixture or fuel-air mixture.
- Wrong fuel type.
- Water in the fuel.
- Clogged air filter.
- Air trapped in hydraulic system.

TROUBLE SHOOTING GUIDE

The engine seems weak.

- Clogged air filter.
- Defective spark plugs.
- Carburetor incorrectly adjusted.
- Air trapped in hydraulic system.

The engine overheats.

- Clogged air intake or cooling fins.
- Engine overloaded.
- Poor ventilation around engine.
- Defective engine speed regulator.
- Soot in the combustion chamber.
- Too little or no oil in the engine.
- Defective spark plugs.
- Pre-ignition incorrect.
- Air trapped in hydraulic system.

Battery not charging.

- Poor contact with battery terminal cable connectors.

The machine moves slowly, unevenly, or not at all.

- Parking brake on.
- Bypass valve on pump open.
- Drive belt for the transmission gears slack or has come off.
- Air trapped in hydraulic system.

Mower deck not engaging.

- Drive belt for the mower deck has come loose.
- Contact for the electromagnetic coupling has loosened.
- The blade switch is faulty or has come loose, from the cable contact.
- The fuse has blown.

Transaxle leaks oil.

- Damaged seals, housing, or gaskets.
- Air trapped in hydraulic system.

TROUBLE SHOOTING GUIDE

Uneven mowing results.

- Different air pressure in the tires on the left and right sides.
- Bent blades.
- The suspending for the mower deck is uneven.
- The chain fixture has come loose.
- The blades are blunt.
- Driving speed too high.
- The grass is too long.
- Grass collected under the mower deck.

The machine vibrates.

- The blades are loose.
 - The blades are incorrectly balanced.
 - The engine is loose.
-

At the end of the mowing season, the machine should be readied for storage (or if it will not be in use for longer than 30 days). Fuel allowed to stand for long periods of time (30 days or more) can leave sticky residues that can plug the carburetor and disrupt engine function.

Fuel stabilizers are an acceptable option as regards to the sticky residues that can occur during storage.

Add stabilizer to the fuel in the tank or in the storage container. Always use the mixing ratios specified by the manufacturer of the stabilizer. Run the engine for at least 10 minutes after adding the stabilizer so that it reaches the carburetor. Do not empty the fuel tank and the carburetor if you have added stabilizer.

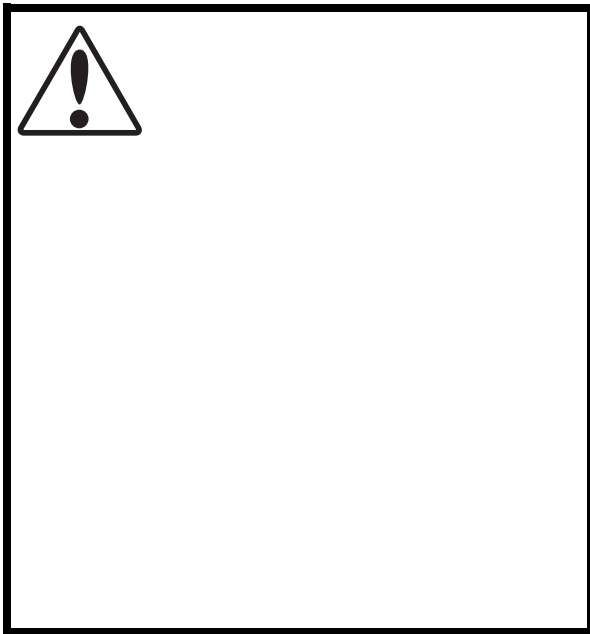

To ready the machine for storage, follow these steps:

1. Thoroughly clean the machine, especially under the mower deck. Touch up damage to the paint and spray a thin layer of oil on the underside of the mower deck to avoid corrosion.
2. Inspect the machine for worn or damaged parts and tighten any nuts or screws that may have become loose.
3. Change the engine oil; dispose of properly.
4. Empty the fuel tanks or add a fuel stabilizer. Start the engine and allow it to run until the carburetor is drained of fuel or the stabilizer has reached the carburetor.
5. Remove the spark plug and pour about a tablespoon of engine oil into the cylinder. Turn over the engine so that the oil is evenly distributed and then refit the spark plug.
6. Lubricate all grease zerks, joints, and axles.
7. Remove the battery. Clean, charge, and store the battery in a cool place, but protect it from direct cold.
8. Store the machine in a clean, dry place and cover it for extra protection.

When ordering spare parts, please specify the purchase year, model, type, and serial number.

Always use genuine Husqvarna spare parts.

An annual check-up at an authorized service workshop is a good way to ensure that your machine performs its best the following season.

WIRING DIAGRAMS

- NOTE:
1. SEAT UNOCCUPIED
 2. BRAKE SWITCH IN OFF POSITION
 3. MOTION CONTROL LEVERS OUT
 4. PTO IN OFF POSITION

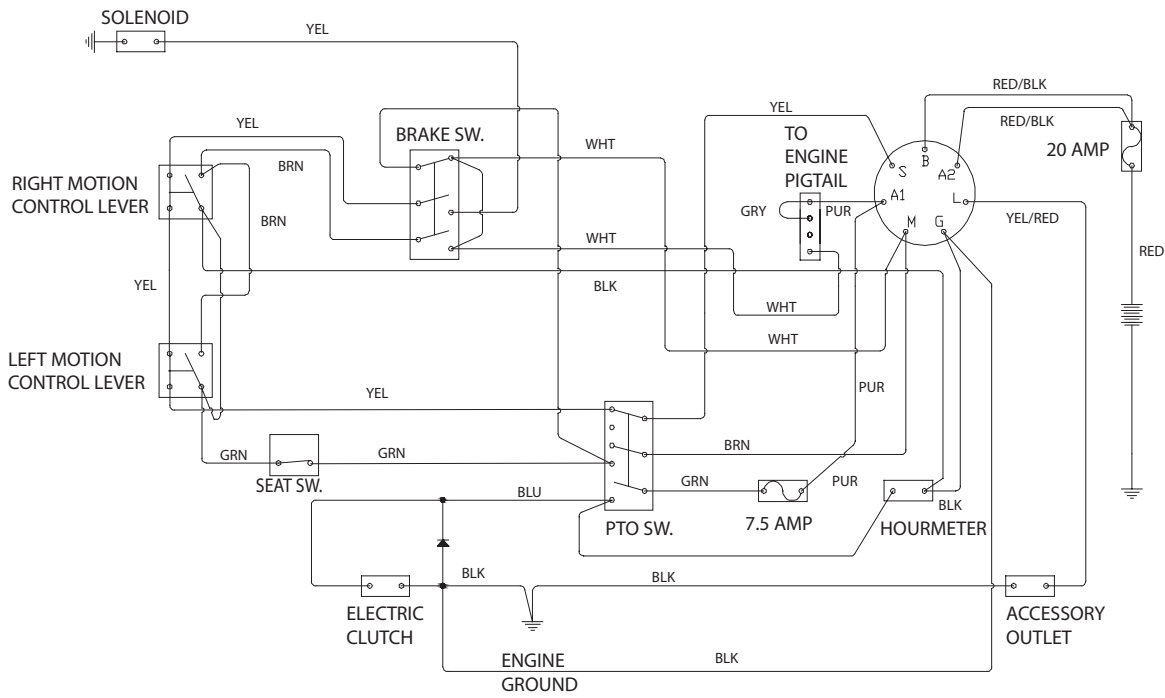

KEY SWITCH POSITIONS

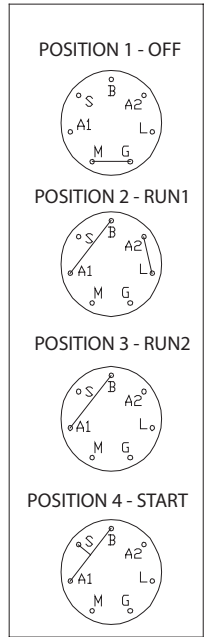

Manufacturer	Briggs & Stratton	Briggs & Stratton
Type	ELS	ELS
Power	26 hp	26 hp
Lubrication	Pressure with oil filter	Pressure with oil filter
Oil capacity excl filter	1.6 qt	1.6 qt
Oil capacity incl filter	1.8 qt	1.8 qt
Engine oil, Synthetic Engine oil, Mineral Class	SAE 5W30, 10W30 SAE 30, (winter 10W30) API , SF, SJ, SH, SG	SAE 5W30, 10W30 SAE 30, (winter 10W30) API , SF, SJ, SH, SG
Fuel	Min 86 octane unleaded (Max methanol 5%, max eth- anol 10%, Max MTBE 15%)	Min 86 octane unleaded (Max methanol 5%, max eth- anol 10%, Max MTBE 15%)
Fuel tank capacity	5 gallon	5 gallon
Spark plugs / gap	NGK - BPR4ES .030" / 0.75 mm	NGK - BPR4ES .030" / 0.75 mm
Cooling	Air cooling	Air cooling
Air filter	Standard	Standard
Alternator	12 V 16 A	12 V 16 A
Starter	Electric 12 V	Electric 12 V
Transmission	ZT2800 Hydro-Gear Non- charged	ZT2800 Hydro-Gear Non- charged
Speed and direction controls	Dual levers, foam gripped	Dual levers, foam gripped
Speed forward	7 mph	7 mph
Speed reverse	4 mph	4 mph
Brakes	Mechanical parking brake	Mechanical parking brake
Front caster tires, Smooth tread	11x4.5-5, 4ply	11x4.5-5, 4ply
Rear tires, Turf pneumatic	18x9.5-8	18x9.5-8
Tire pressure, front and rear	15 PSI / 103 kPa / 1 bar	15 PSI / 103 kPa / 1 bar

Cutting width	44"	50"
Cutting height	1.5"- 4 .5"	1.5"- 4 .5"
Uncut circle	0	0
Number of blades	3	3
Blade length		
Nose rollers	Yes	Yes + 2 anti-scalp rollers
Michigan Seat	Standard	Standard
Hinged armrests	Yes	Yes
Hour meter	Standard	Standard
Blade engagement	Electric clutch	Electric clutch
Deck construction	11 gauge w/10 gauge skirts	11 gauge w/10 gauge skirts
Productivity		
Weight	625lbs (283 kg).	605lbs. (274 kg)
Base machine length	69 1/2" (177 cm)	72" (183 cm)
Base machine width	44" (112 cm)	50" (127 cm)
Base machine height	40" (102 cm)	40" (102 cm)
Overall width, Chute up		
Overall width, Chute down		
Hand/Arm - A(8)	2.44 m/s ²	2.20 m/s ²
Whole Body - A(8)	0.23 m/s ²	0.14 m/s ²
Hand/Arm - a _{hr.eq}	2.82 m/s ²	2.54 m/s ²
Whole Body - a _{hr.eq}	0.27 m/s ²	0.16 m/s ²

Manufacturer	Honda	Honda
Type		
Power	20 hp	20 hp
Lubrication	Pressure with oil filter	Pressure with oil filter
Oil capacity excl filter	1.6 qt	1.6 qt
Oil capacity incl filter	1.8 qt	1.8 qt
Engine oil, Synthetic Engine oil, Mineral Class	SAE 5W30, 10W30 SAE 30, (winter 10W30) API , SF, SJ, SH, SG	SAE 5W30, 10W30 SAE 30, (winter 10W30) API , SF, SJ, SH, SG
Fuel	Min 86 octane unleaded (Max methanol 5%, max eth- anol 10%, Max MTBE 15%)	Min 86 octane unleaded (Max methanol 5%, max eth- anol 10%, Max MTBE 15%)
Fuel tank capacity	5 gallon	5 gallon
Spark plugs / gap	NGK - BPR4ES .030" / 0.75 mm	NGK - BPR4ES .030" / 0.75 mm
Cooling	Air cooling	Air cooling
Air filter	Standard	Standard
Alternator	12 V 16 A	12 V 16 A
Starter	Electric 12 V	Electric 12 V
Transmission	ZT2800 Hydro-Gear	ZT2800 Hydro-Gear
Speed and direction controls	Dual levers, foam gripped	Dual levers, foam gripped
Speed forward	7 mph	7 mph
Speed reverse	4 mph	4 mph
Brakes	Mechanical parking brake	Mechanical parking brake
Front caster tires, Smooth tread	11x4.5-5, 4ply	11x4.5-5, 4ply
Rear tires, Turf pneumatic	18x9.5-8	18x9.5-8
Tire pressure, front and rear	15 PSI / 103 kPa / 1 bar	15 PSI / 103 kPa / 1 bar

Cutting width	44"	50"
Cutting height	1.5"- 4 .5"	1.5"- 4 .5"
Uncut circle	0	0
Number of blades	3	3
Blade length		
Nose rollers	Yes	Yes + 2 anti-scalp rollers
Michigan Seat	Standard	Standard
Hinged armrests	Yes	Yes
Hour meter	Standard	Standard
Blade engagement	Electric clutch	Electric clutch
Deck construction	11 gauge w/10 gauge skirts	11 gauge w/10 gauge skirts
Productivity		
Weight	625lbs (283 kg).	605lbs. (274 kg)
Base machine length	69 1/2" (177 cm)	72" (183 cm)
Base machine width	44" (112 cm)	50" (127 cm)
Base machine height	40" (102 cm)	40" (102 cm)
Overall width, Chute up		
Overall width, Chute down		
Hand/Arm - A(8)	2.44 m/s ²	2.20 m/s ²
Whole Body - A(8)	0.23 m/s ²	0.14 m/s ²
Hand/Arm - a _{hr.eq}	2.82 m/s ²	2.54 m/s ²
Whole Body - a _{hr.eq}	0.27 m/s ²	0.16 m/s ²

Manufacturer	Kohler	Kohler
Type	Courage	Courage
Power	24 hp	24 hp
Lubrication	Pressure with oil filter	Pressure with oil filter
Oil capacity excl filter	1.6 qt	1.6 qt
Oil capacity incl filter	1.8 qt	1.8 qt
Engine oil, Synthetic Engine oil, Mineral Class	SAE 5W30, 10W30 SAE 30, (winter 10W30) API , SF, SJ, SH, SG	SAE 5W30, 10W30 SAE 30, (winter 10W30) API , SF, SJ, SH, SG
Fuel	Min 86 octane unleaded (Max methanol 5%, max eth- anol 10%, Max MTBE 15%)	Min 86 octane unleaded (Max methanol 5%, max eth- anol 10%, Max MTBE 15%)
Fuel tank capacity	5 gallon	5 gallon
Spark plugs / gap	NGK - BPR4ES .030" / 0.75 mm	NGK - BPR4ES .030" / 0.75 mm
Cooling	Air cooling	Air cooling
Air filter	Standard	Standard
Alternator	12 V 16 A	12 V 16 A
Starter	Electric 12 V	Electric 12 V
Transmission	ZT2800 Hydro-Gear	ZT2800 Hydro-Gear
Speed and direction controls	Dual levers, foam gripped	Dual levers, foam gripped
Speed forward	7 mph	7 mph
Speed reverse	4 mph	4 mph
Brakes	Mechanical parking brake	Mechanical parking brake
Front caster tires, Smooth tread	11x4.5-5, 4ply	11x4.5-5, 4ply
Rear tires, Turf pneumatic	18x9.5-8	18x9.5-8
Tire pressure, front and rear	15 PSI / 103 kPa / 1 bar	15 PSI / 103 kPa / 1 bar

Cutting width	44"	50"
Cutting height	1.5"- 4 .5"	1.5"- 4 .5"
Uncut circle	0	0
Number of blades	3	3
Blade length		
Nose rollers	Yes	Yes + 2 anti-scalp rollers
Michigan Seat	Standard	Standard
Hinged armrests	Yes	Yes
Hour meter	Standard	Standard
Blade engagement	Electric clutch	Electric clutch
Deck construction	11 gauge w/10 gauge skirts	11 gauge w/10 gauge skirts
Productivity		
Weight	625lbs (283 kg).	605lbs. (274 kg)
Base machine length	69 1/2" (177 cm)	72" (183 cm)
Base machine width	44" (112 cm)	50" (127 cm)
Base machine height	40" (102 cm)	40" (102 cm)
Overall width, Chute up		
Overall width, Chute down		
Hand/Arm - A(8)	2.44 m/s ²	2.20 m/s ²
Whole Body - A(8)	0.23 m/s ²	0.14 m/s ²
Hand/Arm - a _{hr.eq}	2.82 m/s ²	2.54 m/s ²
Whole Body - a _{hr.eq}	0.27 m/s ²	0.16 m/s ²

Manufacturer	Kawasaki
Type	
Power	21 hp
Lubrication	Pressure with oil filter
Oil capacity excl filter	1.6 qt
Oil capacity incl filter	1.8 qt
Engine oil, Synthetic Engine oil, Mineral Class	SAE 5W30, 10W30 SAE 30, (winter 10W30) API , SF, SJ, SH, SG
Fuel	Min 86 octane unleaded (Max methanol 5%, max eth- anol 10%, Max MTBE 15%)
Fuel tank capacity	5 gallon
Spark plugs / gap	NGK - BPR4ES .030" / 0.75 mm
Cooling	Air cooling
Air filter	Standard
Alternator	12 V 16 A
Starter	Electric 12 V
Transmission	ZT2800 Hydro-Gear
Speed and direction controls	Dual levers, foam gripped
Speed forward	7 mph
Speed reverse	4 mph
Brakes	Mechanical parking brake
Front caster tires, Smooth tread	11x4.5-5, 4ply
Rear tires, Turf pneumatic	18x9.5-8
Tire pressure, front and rear	15 PSI / 103 kPa / 1 bar

Cutting width	50"
Cutting height	1.5"- 4 .5"
Uncut circle	0
Number of blades	3
Blade length	
Nose rollers	Yes + 2 anti-scalp rollers
Michigan Seat	Standard
Hinged armrests	Yes
Hour meter	Standard
Blade engagement	Electric clutch
Deck construction	11 gauge w/10 gauge skirts
Productivity	
Weight	605lbs. (274 kg)
Base machine length	72" (183 cm)
Base machine width	50" (127 cm)
Base machine height	40" (102 cm)
Overall width, Chute up	
Overall width, Chute down	
Hand/Arm - A(8)	2.20 m/s ²
Whole Body - A(8)	0.14 m/s ²
Hand/Arm - a _{hr.eq}	2.54 m/s ²
Whole Body - a _{hr.eq}	0.16 m/s ²

BioClip attachment (Mulch kit)

Collection system

·Engine crankshaft bolt	50 ft/lb (67 Nm)
·Deck pulley bolts	45 ft/lb (61 Nm)
·Lug nuts	75 ft/lb (100 Nm)
·Blade bolt	45-55 ft/lb (60-75 Nm)
·Standard 1/4" fasteners	9 ft/lb (12 Nm)
·Standard 5/16" fasteners	18 ft/lb (25 Nm)
·Standard 3/8" fasteners	33 ft/lb (44 Nm)
·Standard 7/16" fasteners	52 ft/lb (70 Nm)
·Standard 1/2" fasteners	80 ft/lb (110 Nm)

When this product is worn out and no longer used, it should be returned to the reseller or other party for recycling.



Labels are placed on the engine and/or in the engine compartment stating that the machine will fulfill the requirements. This is also applicable to special requirements for any of the states, (Californian emission rules etc.). Do not remove any of these labels. Certificates can also be supplied with the machine at delivery or written in the Engine manual. Take care of them as they are valuable documents.

Vibration data corresponding to Directive 2002/44/EC is given in the Technical Data Section.
The Declaration of Conformity is included in the literature packet.

<p>1. Charge the battery.</p> <p>2. Adjust the tire pressure of all wheels to 15 PSI (1 bar).</p> <p>3. Mount the steering controls in the normal position.</p> <p>4. Connect the contact box to the cable for the seat’s safety switch.</p> <p>5. Check that the right amount of oil is in the engine.</p> <p>6. Adjust the position of the steering controls.</p> <p>7. Fill with fuel and open the fuel shut off valve.</p> <p>8. Start the engine.</p> <p>9. Check that there is drive to both wheels.</p> <p>10. Check the mower deck adjustment.</p> <p>11. Check:</p> <p> The safety switch for the parking brake.</p> <p> The safety switch for the mower deck.</p> <p> The safety switch in the seat.</p> <p> The safety switch in the steering controls.</p> <p> Parking brake functionality.</p> <p> Driving forward.</p> <p> Driving backward.</p> <p> Engaging the blades.</p> <p>12. Check the idle speed</p> <p>13. Check the engine high idle speed</p> <p>14. Inform the customer about:</p> <p> The need and advantages of following the service schedule.</p> <p> The need and advantages of leaving the machine for service every 300 hours.</p> <p> The effects of service and maintaining a service journal on the machine’s resale value.</p> <p> Application areas for Mulching.</p> <p>15. Fill in the sales papers, etc.</p>	<p><input type="checkbox"/></p> <p><input type="checkbox"/></p> <p><input type="checkbox"/></p> <p><input type="checkbox"/></p> <p><input type="checkbox"/></p> <p><input type="checkbox"/></p> <p><input type="checkbox"/></p> <p><input type="checkbox"/></p> <p><input type="checkbox"/></p> <p><input type="checkbox"/></p> <p><input type="checkbox"/></p> <p><input type="checkbox"/></p> <p><input type="checkbox"/></p> <p><input type="checkbox"/></p> <p><input type="checkbox"/></p> <p><input type="checkbox"/></p> <p><input type="checkbox"/></p> <p><input type="checkbox"/></p> <p><input type="checkbox"/></p> <p><input type="checkbox"/></p> <p><input type="checkbox"/></p> <p>Delivery service has been carried out.</p> <p>No remaining notes.</p> <p>Certified:</p>

1. Change engine oil.	<input type="checkbox"/>
-----------------------	--------------------------

-
-
- | | |
|---|--|
| | |
| <ol style="list-style-type: none">1. Check the fuel pump's air filter.2. Sharpen/Replace mower blades if required.3. Check the tire pressures.4. Check battery with cables.5. Lubricate according to lubrication chart.6. Check/clean the engine's cooling air intake.7. Clean the air cleaner's pre-filter (foam). | |
| | |

-
-
- | | |
|--|--|
| | |
| <ol style="list-style-type: none">1. Perform the 25-hour service.2. Clean/replace the air cleaner's filter cartridge (paper filter) (shorter intervals for dusty operating conditions).3. Change engine oil.4. Lubricate according to lubrication chart.5. Check/adjust the parking brake. | |
| | |

-
-
- | | |
|--|--|
| | |
| <ol style="list-style-type: none">1. Perform the 25-hour service.2. Perform the 50-hour service.3. Change the engine oil filter.4. Clean/replace the spark plugs.5. Replace the fuel filter.6. Clean the cooling fins on the engine and transmission.7. Check V-belts.8. Check tighten caster wheel axle bolts (every 200 hours).9. Change the air filter's paper cartridge. | |
| | |

I pct the machine. Come a reemen 6(wit)-6h the 6(cc-7(u)16sc-7(to)-5(m)16e)-5(r)16 - tion4(al work is()-6to be)47(ca)47rrt.-. Perform

-
-
- | | |
|--|--|
| | |
| <ol style="list-style-type: none">1. Clean the engine's cooling air intake (25 hours).2. Replace the air cleaner's pre-filter (foam) (300 hours).3. Replace the air filter's paper cartridge.4. Change the engine oil (50 hours).5. Replace the engine oil filter (100 hours).6. Check/adjust the cutting height.7. Check/adjust the parking brake (50 hours).8. Clean/Change the spark plugs (100 hours).9. Change the fuel filter (100 hours).10. Clean the cooling fins (100 hours).11. Check the engine valve clearance.12. Perform the 300-hour service at an authorized service workshop. | |
| | |

WARRANTY

DIXON® ZTR® COMMERCIAL / RESIDENTIAL WARRANTY POLICY **RAM 44, RAM 50, RAM 44 MAG™, RAM 50 MAG™** **RAM ULTRA 50, RAM ULTRA 60 & RAM ULTRA 72**

DIXON® WARRANTS ITS ZTR® MOWERS AGAINST DEFECTS IN MATERIAL AND WORKMANSHIP FOR THE PERIODS SET FORTH BELOW.

THE SOLE REMEDY UNDER THIS WARRANTY IS REPLACEMENT OR REPAIR OF PARTS INCLUDING LABOR COSTS.

THIS WARRANTY IS SUBJECT TO THE FOLLOWING CONDITIONS AND LIMITATIONS:

1. **COMMERCIAL WARRANTY** (use other than, or in addition to, mowing at owner's primary place of residence):
 - a. One Year - 100% parts and labor subject to the conditions and limitations described herein for a period of one year from date of purchase by the original owner.
 - b. Attachments marketed through or approved by Dixon are warranted for one year parts and labor in commercial use applications.
 - c. The RAM 44, RAM 50, RAM 44 MAG™, RAM 50 MAG™ RAM ULTRA 50, RAM ULTRA 60 and RAM ULTRA 72 are not subject to hour meter restrictions.
 - d. Warranty applies to new mowers.
2. **RESIDENTIAL WARRANTY** (used only at owner's primary place of residence):
 - a. Two years - 100% parts and labor subject to the conditions and limitations described herein for a period of two years from date of purchase by the original owner.
 - b. Third year - limited to 100% parts cost as shown in the current Dixon® Parts Price List and subject to the conditions and limitations as described herein.
 - c. Attachments marketed through or approved by Dixon are warranted for two years parts and labor in residential use applications.
 - d. Warranty applies to new mowers.
3. All Dixon® warranty must be accomplished by authorized Dixon® dealers and in accordance with Dixon® warranty policy and allowances. All warranty claims must be submitted to Dixon for approval.
4. Warranty labor reimbursement to dealers based on published Dixon® flat rate schedule.
5. Warranty does not apply to damage in transit or incidents of misuse, negligence, accidents, or alteration. The use of parts or components other than those supplied by Dixon **VOIDS ALL WARRANTY.**
6. Battery warranty is limited to 1 year from mower manufacture date.
7. The following items are not covered by this warranty policy:
 - a. Routine maintenance or adjustments to include any oils, filters or other fluids used.
 - b. Belts, blades, tires and cosmetic appearance (paint, seat fade, etc.)
 - c. Pick up and delivery charges for transportation of mower to and from an authorized Dixon® dealer's place of business.
 - d. Engines. These are covered under a separate warranty by each individual engine manufacturer. Consult engine manual for warranty details.
 - e. Any costs or expense of providing substitute equipment while repair work is being performed on a warranted mower.
8. **THERE IS NO OTHER EXPRESS WARRANTY. TO THE EXTENT PERMITTED BY LAW, ALL IMPLIED WARRANTIES, INCLUDING THOSE OF MERCHANTABILITY AND FITNESS FOR A PARTICULAR PURPOSE ARE EXCLUDED, OTHERWISE, ALL SUCH IMPLIED WARRANTIES ARE LIMITED TO THE SAME DURATION AND REMEDIES AS THE EXPRESS WARRANTY. ALL LIABILITIES FOR CONSEQUENTIAL DAMAGES UNDER ANY EXPRESS OR IMPLIED WARRANTY ARE EXCLUDED.**

DIXON ZTR.